



SL216[®]

Mechanically Seamed Roof System

Technical / Installation Information



www.vulcansteel.com
1-800-258-3369

IMPORTANT NOTICE

READ THIS MANUAL COMPLETELY PRIOR TO BEGINNING THE INSTALLATION OF THE **SL216®** ROOFING SYSTEM. THE MANUFACTURER DETAILS MUST BE FOLLOWED AS A MINIMUM TO INSURE APPROPRIATE WARRANTIES WILL BE ISSUED.

ALWAYS INSPECT EACH AND EVERY PANEL AND ALL ACCESSORIES BEFORE INSTALLATION. NEVER INSTALL ANY PRODUCT IF ITS QUALITY IS IN QUESTION. NOTIFY VULCAN IMMEDIATELY IF ANY PRODUCT IS BELIEVED TO BE OUT OF TOLERANCE, SPECIFICATION OR HAS BEEN DAMAGED DURING SHIPMENT.

IF THERE IS A CONFLICT BETWEEN PROJECT INSTALLATION DRAWINGS PROVIDED OR APPROVED BY THE MANUFACTURER AND DETAILS IN THIS MANUAL, PROJECT INSTALLATION DRAWINGS WILL TAKE PRECEDENCE.

Ice Dam Disclaimer

VULCAN designs its standing seam roofs to meet the load requirements dictated by governing codes and project specifications, including applicable snow loads. However, VULCAN expressly disclaims responsibility for weathertightness or roof point loading issues or other hazards resulting from ice dam situations. Any time ice and snow can melt on the main body of the roof and refreeze at the eave or in the shadow of an adjacent wall, an ice dam situation may develop. In addition to local climate, ice dam formation is affected by many other factors, including but not limited to, roof insulation R value, roof panel color, interior temperature of building, heater location in building, eave overhangs, parapet walls, shading of building roof areas from adjacent trees, parapets, buildings, etc. These factors are design and maintenance issues and are outside the control of VULCAN. VULCAN specifically disclaims any liability for damage due to ice dam formation, although the following issues should be taken into consideration concerning standing seam roofs installed in freezing climates:

- Always use field seamed panels. These machine-folded seams are more durable when subjected to occasional icing.
- Eliminate “cold” eave overhangs and parapet walls from the building design. Roof overhangs outside the heated envelope of the building will tend to be colder than the roof areas over the heated envelope. Simple roof designs are preferred. Parapet walls at the eave allow ice and snow to collect due to shading effects and the lower roof temperatures caused thereby.
- Make sure the interior of the building is adequately insulated and the heating is properly distributed. Inadequate insulation in the roof and/or improper heat distribution causes heat flow through the main body of the roof. On days when the temperature is below freezing, this heat gain can cause ice and snow to melt and refreeze at the eave where the roof is colder.
- Lay out the building to prevent the eaves and other roof areas from being shaded during the winter. This may mean eliminating adjacent trees or reconsidering roof geometries.
- Consider using self-regulating heating cables at the eaves to mitigate the effects of ice dams.
- On building designs using attics, over-insulate the attic floor and provide adequate ventilation in the attic. This will reduce heat transfer through the roof resulting in more consistent roof temperatures between eave and field of roof.
- Increase the degree of diligence with respect to underlayment materials at roof areas prone to icing. This may include valleys, eaves, dormers and roof areas near dormers, parapets and the like where shading may occur.

For more information on this subject, please refer to the MCA’s Metal Roof Design For Cold Climates manual.

The engineering data contained herein is for the expressed use of customers and design professionals. Along with this data, it is recommended that the design professional have a copy of the most current version of the North American Specification for the Design of Cold-Formed Steel Structural Members published by the American Iron and Steel Institute to facilitate design. This Specification contains the design criteria for cold-formed steel components. Along with the Specification, the designer should reference the most current building code applicable to the project jobsite in order to determine environmental loads. If further information or guidance regarding cold-formed design practices is desired, please contact the manufacturer

©Copyright VULCAN Steel Structures, Inc. 2024 All Rights Reserved

Descriptions and specifications contained herein were in effect at the time this publication was approved for printing. In a continuing effort to refine and improve products, VULCAN reserves the right to discontinue products at any time or change specifications and/or designs without incurring obligation. **To ensure you have the latest information available, please inquire or visit our website at www.vulcansteel.com.** Application details are for illustration purposes only and may not be appropriate for all environmental conditions, building designs or panel profiles. Projects should be designed to conform to applicable building codes, regulations and accepted industry practices. If there is a conflict between this manual and project erection drawings, the erection drawings will take precedence.

V-2-24

TABLE OF CONTENTS

ROOFING SYSTEM

General Description	SL-3
Architect/Engineering Information.....	SL-4

ENGINEERING

Read This First	SL-5
UL 90 Requirements.....	SL-6
12" Properties/Load Tables	SL-7 – SL-8
16" Properties/Load Tables	SL-9 – SL-10

GENERAL INFORMATION

Product Checklist.....	SL-11 – SL-20
Panel Orientation	SL-21
Installation Guidelines.....	SL-21
Preparatory Requirements.....	SL-22
Unloading.....	SL-23 – SL-24
Handling/Panel Storage.....	SL-25
Proper Handling, Storage and Maintenance of Painted and Galvalume Plus® Panels	SL-26 – SL-27

INSTALLATION SEQUENCE

Step 1 — Rake Attachments	SL-28
Step 2 — Low System Eave.....	SL-29
Step 2A — High System Eave	SL-30
Step 3 — Thermal Spacer (For High Systems Only)	SL-31
Step 4 — First Panel	SL-32
Step 5 — Clip Installation	SL-33
Step 6 — Endlap.....	SL-34
Step 7 — Ridge	SL-35
Step 8 — Subsequent Runs Eave.....	SL-36
Step 9 — Subsequent Runs Endlap.....	SL-37
Step 10 — Subsequent Runs Ridge.....	SL-38
Step 11 — Last Panel Run	SL-39
Step 12 — Seaming Operation.....	SL-40 – SL-42
Step 13 — Outside Closure Installation.....	SL-43

SPECIAL ERECTION TECHNIQUES

UL 90 Light Transmitting Panel Installation	SL-44
Riveted Rail Light Transmitting Panel Installation	SL-45 – SL-48
Curb Installation	SL-48 – SL-66
Pipe Penetration Installation	SL-67 – SL-68

DETAILS

Open Framing

Fixed Eave With Sculptured Gutter	SL-69
Fixed Eave With Sculptured Eave Trim.....	SL-70
Fixed Eave With Box Eave Trim.....	SL-71
Floating Ridge.....	SL-72
Floating Vented Ridge	SL-73
Fixed Vented Eave	SL-74
Sculptured Rake	SL-75
Sculptured Rake With Cleat	SL-76
Parapet Rake.....	SL-77
Floating Sculptured High Side Eave.....	SL-78
Parapet Floating High Side Eave	SL-79
Fixed Valley.....	SL-80
Floating Hip.....	SL-81

TABLE OF CONTENTS

Wood Deck

Field Hemming Panel End SL-82
 Floating Endlap SL-83
 Floating Eave with Box Gutter SL-84
 Floating Eave with Eave Trim with Extended Drip Edge..... SL-85
 Fixed Ridge..... SL-86
 Fixed Vented Ridge SL-87
 Box Rake..... SL-88
 Parapet Rake..... SL-89
 Fixed Box High Side Eave..... SL-90
 Parapet Fixed High Side Eave SL-91
 Floating Valley SL-92
 Fixed Hip..... SL-93

Rigid Insulation Over Metal Deck

Floating Endlap..... SL-94
 Floating Eave With Box Gutter SL-95
 Floating Eave With Eave Trim with Extended Drip Edge SL-96
 Fixed Ridge..... SL-97
 Fixed Vented Ridge SL-98
 Box Rake..... SL-99
 Parapet Rake..... SL-100
 Fixed Box High Side Eave..... SL-101
 Parapet Fixed High Side Eave SL-102
 Floating Valley SL-103
 Fixed Hip SL-104

ROOFING SYSTEM

GENERAL DESCRIPTION

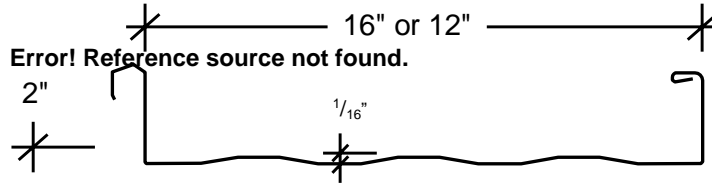

Coverage Width - 16" or 12"

Minimum Slope - 1/2:12

Panel Attachment - Low, High (Fixed or Floating) or Utility (No insulation clearance)

Panel Substrate - Galvalume® (standard)

Gauge - Standard: 24 ; Optional: 22

Finishes - Smooth Striated (standard)* or Embossed Striated

Coatings – Standard Color, KYNAR, KYNAR Metallic

PRODUCT SELECTION CHART

PRODUCT	Signature® 300 Metallic		Signature® 300		Signature® 200		Galvalume Plus®	
	24 Ga.	22 Ga.	24 Ga.	22 Ga.	24 Ga.	22 Ga.	24 Ga.	22 Ga.
SL216® HS								
16" Wide	■	■	■	■	■	■	●	■
12" Wide	■	■	■	■	■	■	●	■

Signature is a registered trademark of NCI Group, Inc. Galvalume Plus is a registered trademark of BIEC International.

- — Available in any quantity.
- — Minimum quantity may be required.

Other colors, finishes, gauges, and materials available; please inquire.

* Striated panels are standard to reduce "oil canning".

CAUTION
Diaphragm capabilities and purlin stability are not provided by manufacturer's SL216® roof system. Therefore, other bracing may be required to conform to A.I.S.C. or A.I.S.I. specifications.

ROOFING SYSTEM

ARCHITECT/ENGINEER INFORMATION

1. **SL216®** is a mechanically seamed roof system. **SL216®** panels are available in 12" and 16" widths. Factory applied mastic inside of female leg of panel is standard.
2. **SL216®** is a structural roofing panel. This panel can be installed directly over purlins or bar joists. It does not require a solid substructure for support. The **SL216®** roof system has several different UL 90 construction numbers.
3. **SL216®** is recommended for roof slopes of ½:12 or greater.
4. Weathertight and aesthetically pleasing endlaps may be accomplished through the use of swaged panels. The manufacturer provides a prepunched back-up plate at the endlap for weathertightness. Swaged endlaps require the roof erection to proceed from right to left as viewed from the eave looking toward the ridge. Roofs with no endlaps and less than 6:12 may be erected from either direction.
5. Heavier gauges, striations and embossing minimize oil canning. Industry standard is a minimum 24 gauge material. Striations are standard to reduce oil canning. Oil canning is not a cause for rejection.
6. Substructure must be on an even plane from eave to ridge to avoid panel distortion (¼" in 20', ⅜" in 40' tolerance).
7. All panels require end sealant at eave and valley conditions; however, for illustration purposes, this sealant is not shown on all drawings.
8. For proper fastener application, see Product Checklist.
9. All perimeter trim dimensions in this manual are based on a wall panel thickness of 1¼" ("PBR" Panel). Any variation from this wall panel thickness may affect the perimeter trim dimensions.
10. The information in this manual is believed to be correct and accurate.
11. Drawings in this manual utilize the low floating clip. Clips are available in low or high fixed, low or high floating and utility.
12. **Avoid restricting the thermal expansion and contraction of the **SL216®** panels. (i.e.: Do not attach panel to the substructure at both the eave and ridge.) However, panels must be attached to the substructure at one end to prevent their sliding down slope.**
13. **SL216® panels are not designed to be work platforms.** Avoid any unnecessary foot traffic on **SL216®** panels. If foot traffic is required, protect the roof panels by using soft soled shoes and some type of roof pad, temporary deck, or walkway.
14. **WARNING: Light transmitting panels are not designed or intended to bear the weight of any person walking, stepping, standing or resting on them. THE MANUFACTURER DISCLAIMS ANY WARRANTY OR REPRESENTATION, EXPRESS OR IMPLIED, that any person can safely walk, step, stand or rest on or near these light transmitting panels or that they comply with any OSHA regulation.**
15. A vapor retarder may be necessary to protect roofing components when high interior humidity is a factor. The need for a vapor retarder, as well as the type, placement and location should be determined by an architect or engineer. The following are examples of conditions that may require a vapor retarder: (A) Projects where outside winter temperatures below 40°F are anticipated and where average winter interior relative humidity of 45% or greater is expected. (B) Building usages with high humidity interiors, such as indoor swimming pools, textile manufacturing operations, food, paper or other wet-process industrial plants. (C) Construction elements that may release moisture after the roof is installed, such as interior concrete and masonry, plaster finishes and fuel burning heaters.
16. Field cutting of the panels should be avoided where possible. If field cutting is required, the panels must be cut with nibblers, snips, or shears to prevent edge rusting. **Do not cut the panels with abrasive saw blades, grinders, or torches.**

CAUTION

Application and design details are for illustration purposes only, and may not be appropriate for all environmental conditions or building designs. Projects should be engineered to conform to applicable building codes, regulations, and accepted industry practices.

ENGINEERING

IMPORTANT READ THIS FIRST

CAUTION

The use of any field seaming machine other than that provided by the manufacturer will damage the panels and void all warranties and will void all engineering data.

Low Floating System - With or without $\frac{3}{8}$ " thermal spacer. **See Insulation/Thermal Spacer Selection Chart below.**

High Floating System - With $\frac{3}{8}$ ", $\frac{5}{8}$ " or 1" thermal spacer. **See Insulation/Thermal Spacer Selection Chart below.**

Thermal calculations should be performed for each project to ensure that the thermal movement of the roof is not greater than the floating clip's capacity. Various densities of blanket insulation may affect the installation and or the appearance of a metal roof system. The installer is responsible for selecting the proper clip and thermal spacer for their conditions.

Insulation/Thermal Spacer Selection Chart

Insulation Thickness	Low System	High System
No Insulation	$\frac{3}{8}$ " Thermal Spacer	High System Not Recommended
3" Insulation	Thermal Spacer Not Recommended	$\frac{5}{8}$ " Thermal Spacer
4" Insulation	Thermal Spacer Not Recommended	$\frac{3}{8}$ " Thermal Spacer
6" Insulation	Low System Not Recommended	Thermal Spacer Not Recommended

Warning

As with all standing seam roof systems, sound attenuation (example: blanket insulation) should be installed between the panels and open framing, such as purlins or joists, to prevent "roof rumble" during windy conditions.

Applications over solid deck such as rigid insulation over a metal deck or a wood deck may require additional acoustical consideration to ensure that thermal vibration noises are isolated from the building interior. This is especially important if the bottom of the deck is left open to the interior, in cathedral ceiling applications or when the attic space is used as a return air plenum.

A vapor retarder may be necessary to protect roofing components when high humidity is a factor. The need for a vapor retarder, as well as the type, placement and location should be determined by an architect or engineer. The following are examples of conditions that may require a vapor retarder: (A) a project where outside winter temperatures below 40 degrees F. are anticipated and where average winter interior relative humidity of 45% or greater is expected. (B) building usages with high humidity interiors such as indoor swimming pools, textile manufacturing operations, food, paper or other wet-process industrial plants. (C) Construction elements that may release moisture after the roof is installed, such as interior concrete, masonry or plaster work and fuel burning heaters.

Error! Reference source not found.

SUBJECT TO CHANGE WITHOUT NOTICE

SEE www.vulcansteel.com FOR CURRENT INFORMATION

SL-03

ENGINEERING

FLORIDA BUILDING CODE PRODUCT APPROVAL

SL216® Roofing System details and engineering load tables have been examined by the State of Florida and comply with the 2023 Florida Building Code Product Approval Number (FL#5346.3 R7).

ENGINEERING

SL216® Panel

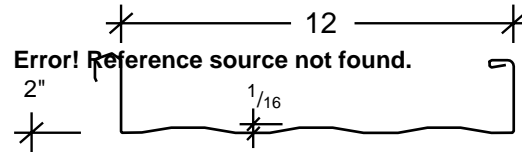

SECTION PROPERTIES								
			NEGATIVE BENDING			POSITIVE BENDING		
PANEL	F _y	WEIGHT	I _{xe}	S _{xe}	Maxo	I _{xe}	S _{xe}	Maxo
GAUGE	(KSI)	(PSF)	(IN.4/FT.)	(IN.3/FT.)	(KIP-IN.)	(IN.4/FT.)	(IN.3/FT.)	(KIP-IN.)
24	50	1.47	0.0756	0.0711	2.1307	0.1667	0.1025	3.0693
22	50	1.83	0.1053	0.1027	3.0751	0.2231	0.1387	4.1551

NOTES:

- All calculations for the properties of SL216 panels are calculated in accordance with the 2012 edition of the North American Specification For Design Of Cold-Formed Steel Structural Members.
- I_{xe} is for deflection determination.
- S_{xe} is for bending.
- Maxo is allowable bending moment.
- All values are for one foot of panel width.

The Engineering data contained herein is for the expressed use of customers and design professionals. Along with this data, it is recommended that the design professional have a copy of the most current version of the North American Specification for the Design of Cold-Formed Steel Structural Members published by the American Iron and Steel Institute to facilitate design. This Specification contains the design criteria for cold-formed steel components. Along with the Specification, the designer should reference the most current building code applicable to the project jobsite in order to determine environmental loads. If further information or guidance regarding cold-formed design practices is desired, please contact the manufacturer.

ENGINEERING

SL216® Panel

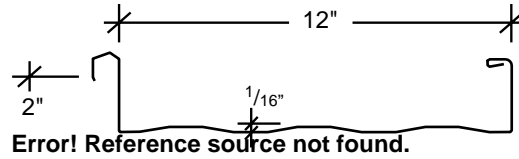

ALLOWABLE UNIFORM LOADS IN POUNDS PER SQUARE FOOT

24 Gauge (Fy = 50 KSI)								
SPAN TYPE	LOAD TYPE	SPAN IN FEET						
		2.5	3.0	3.5	4.0	4.5	5.0	5.5
SINGLE	LIVE	216.0	180.0	154.3	127.9	101.0	81.8	67.6
2-SPAN	LIVE	216.0	157.8	116.0	88.8	70.1	56.8	47.0
3-SPAN	LIVE	216.0	180.0	144.9	111.0	87.7	71.0	58.7
4-SPAN	LIVE	216.0	180.0	135.3	103.6	81.9	66.3	54.8

22 Gauge (Fy = 50 KSI)								
SPAN TYPE	LOAD TYPE	SPAN IN FEET						
		2.5	3.0	3.5	4.0	4.5	5.0	5.5
SINGLE	LIVE	313.0	260.8	223.6	173.1	136.8	110.8	91.6
2-SPAN	LIVE	313.0	227.8	167.4	128.1	101.2	82.0	67.8
3-SPAN	LIVE	313.0	260.8	209.2	160.2	126.5	102.5	84.7
4-SPAN	LIVE	313.0	260.8	195.3	149.5	118.2	95.7	79.1

NOTES:

1. THE ABOVE LOADS ARE NOT FOR USE WHEN DESIGNING PANELS TO RESIST WIND UPLIFT.
2. Strength calculations based on the 2012 AISI Standard "North American Specification for the Design of Cold-formed Steel Structural Members."
3. Allowable loads are applicable for uniform loading and spans without overhangs.
4. LIVE load capacities are for those loads that push the panel against its supports. The applicable limit states are flexure, shear, combined shear and flexure, web crippling at end and interior supports, and a deflection limit of L/180 under strength-level loads.
5. Panel pullover and Screw pullout capacity must be checked separately using the screws employed for each particular application when utilizing this load chart.
6. The use of any field seaming equipment or accessories including but not limited to clips, fasteners, and support plates other than tha provided by the manufacturer may (eave, backup, rake, etc.) damage panels, void all warranties and will void all engineering data.
7. This material is subject to change without notice. Please contact VULCAN for the most current data.

The Engineering data contained herein is for the expressed use of customers and design professionals. Along with this data, it is recommended that the design professional have a copy of the most current version of the *North American Specification for the Design of Cold-Formed Steel Structural Members* published by the American Iron and Steel Institute to facilitate design. This Specification contains the design criteria for cold-formed steel components. Along with the Specification, the designer should reference the most current building code applicable to the project jobsite in order to determine environmental loads. If further information or guidance regarding cold-formed design practices is desired, please contact the manufacturer.

ENGINEERING

SL216® Panel

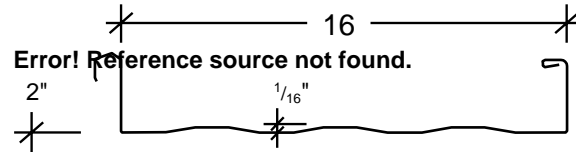

SECTION PROPERTIES								
			NEGATIVE BENDING			POSITIVE BENDING		
PANEL	F _y	WEIGHT	I _{xe}	S _{xe}	Maxo	I _{xe}	S _{xe}	Maxo
GAUGE	(KSI)	(PSF)	(IN.4/FT.)	(IN.3/FT.)	(KIP-IN.)	(IN.4/FT.)	(IN.3/FT.)	(KIP-IN.)
24	50	1.38	0.0574	0.0538	1.6096	0.1324	0.0779	2.3324
22	50	1.72	0.0794	0.0776	2.325	0.1779	0.1057	3.1654

NOTES:

1. All calculations for the properties of SL216 panels are calculated in accordance with the 2012 edition of the North American Specification For Design Of Cold-Formed Steel Structural Members.
2. I_{xe} is for deflection determination.
3. S_{xe} is for bending.
4. Maxo is allowable bending moment.
5. All values are for one foot of panel width.

The Engineering data contained herein is for the expressed use of customers and design professionals. Along with this data, it is recommended that the design professional have a copy of the most current version of the North American Specification for the Design of Cold-Formed Steel Structural Members published by the American Iron and Steel Institute to facilitate design. This Specification contains the design criteria for cold-formed steel components. Along with the Specification, the designer should reference the most current building code applicable to the project jobsite in order to determine environmental loads. If further information or guidance regarding cold-formed design practices is desired, please contact the manufacturer.

ENGINEERING

SL216® Panel

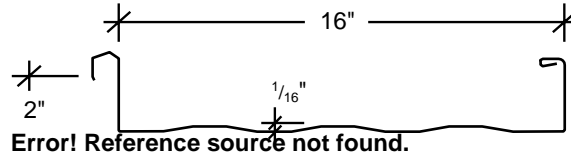

ALLOWABLE UNIFORM LOADS IN POUNDS PER SQUARE FOOT

24 Gauge (Fy = 50 KSI)								
SPAN TYPE	LOAD TYPE	SPAN IN FEET						
		2.5	3.0	3.5	4.0	4.5	5.0	5.5
SINGLE	LIVE	162.0	135.0	115.7	97.2	76.8	62.2	51.4
2-SPAN	LIVE	162.0	119.2	87.6	67.1	53.0	42.9	35.5
3-SPAN	LIVE	162.0	135.0	109.5	83.8	66.2	53.7	44.3
4-SPAN	LIVE	162.0	135.0	102.2	78.3	61.8	50.1	41.4

22 Gauge (Fy = 50 KSI)								
SPAN TYPE	LOAD TYPE	SPAN IN FEET						
		2.5	3.0	3.5	4.0	4.5	5.0	5.5
SINGLE	LIVE	233.4	194.5	166.7	131.9	104.2	84.4	69.8
2-SPAN	LIVE	233.4	172.2	126.5	96.9	76.5	62.0	51.2
3-SPAN	LIVE	233.4	194.5	158.2	121.1	95.7	77.5	64.0
4-SPAN	LIVE	233.4	194.5	147.7	113.1	89.3	72.4	59.8

NOTES:

- 1. THE ABOVE LOADS ARE NOT FOR USE WHEN DESIGNING PANELS TO RESIST WIND UPLIFT.**
- Strength calculations based on the 2012 AISI Standard "North American Specification for the Design of Cold-formed Steel Structural Members."
- Allowable loads are applicable for uniform loading and spans without overhangs.
- LIVE load capacities are for those loads that push the panel against its supports. The applicable limit states are flexure, shear, combined shear and flexure, web crippling at end and interior supports, and a deflection limit of L/180 under strength-level loads.
- Panel pullover and Screw pullout capacity must be checked separately using the screws employed for each particular application when utilizing this load chart.
- The use of any field seaming equipment or accessories including but not limited to clips, fasteners, and support plates other than tha provided by the manufacturer may (eave, backup, rake, etc.) damage panels, void all warranties and will void all engineering data.
- This material is subject to change without notice. Please contact VULCAN for the most current data.

The Engineering data contained herein is for the expressed use of customers and design professionals. Along with this data, it is recommended that the design professional have a copy of the most current version of the *North American Specification for the Design of Cold-Formed Steel Structural Members* published by the American Iron and Steel Institute to facilitate design. This Specification contains the design criteria for cold-formed steel components. Along with the Specification, the designer should reference the most current building code applicable to the project jobsite in order to determine environmental loads. If further information or guidance regarding cold-formed design practices is desired, please contact the manufacturer.

GENERAL INFORMATION

PRODUCT CHECKLIST

<p>SL216® Panel</p> <p>Error! Reference source not found. 2" 1/16"</p> <p>12" <input type="radio"/></p> <p>16" <input type="radio"/></p>	<p>Back-Up Plate</p> <ul style="list-style-type: none"> • For use at ridge and endlaps • 16 gauge
<p>Clip, Floating</p> <p>LOW 2 3/8"</p> <p>HIGH 3"</p> <ul style="list-style-type: none"> • Low – For use with or without 3/8" thermal spacer. <p>HW-230 <input type="radio"/></p> <ul style="list-style-type: none"> • High – For use with 3/8", 5/8" or 1" thermal spacer. <p>HW-232 <input type="radio"/></p>	<p>Rake Support</p> <ul style="list-style-type: none"> • 20'-0" length • 14 gauge • Factory slots • For use with low or high clip <p>LOW 2 3/8"</p> <p>3 1/2"</p> <p>HIGH 3"</p> <p>2 7/8"</p> <ul style="list-style-type: none"> HW-7712 - Low <input type="radio"/> HW-7722 - High <input type="radio"/>
<p>Clip, Fixed</p> <p>LOW 3"</p> <p>HIGH 3"</p> <ul style="list-style-type: none"> • Low – For use with or without 3/8" thermal spacer <p>HW-236 <input type="radio"/></p> <ul style="list-style-type: none"> High – For use with 3/8", 5/8" or 1" thermal spacer <p>HW-234 <input type="radio"/></p>	<p>Bearing Plate Standard</p> <ul style="list-style-type: none"> • 16 gauge • For use with low or utility systems • For use with rigid board insulation <p>5"</p> <p>3 7/8"</p> <p>HW-7500 <input type="radio"/></p>

GENERAL INFORMATION

PRODUCT CHECKLIST

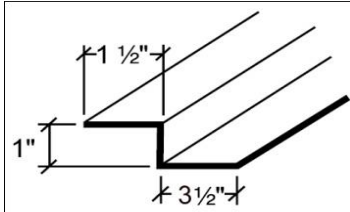
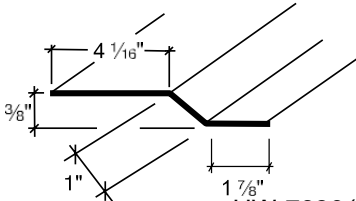
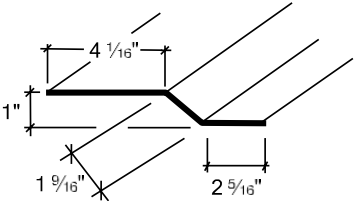
<p>Eave Plate, Low</p> <ul style="list-style-type: none"> • 8'-0" length • 14 gauge <p>Error! Reference source not found.</p> <p>HW-7600 ○</p>	<p>Eave Plate, High</p> <ul style="list-style-type: none"> • 8'-0" length • 14 gauge <p>not found.</p>  <p>VHEP ○</p>
<p>Floating Eave Plate, Low</p> <ul style="list-style-type: none"> • 8'-0" length • 14 gauge <p>Error! Reference source not found.</p> <p>HW-7617 ○</p>	<p>Floating Eave Plate, High</p> <ul style="list-style-type: none"> • 8'-0" length • 14 gauge <p>Error! Reference source not found.</p> <p>HW-7618 ○</p>
<p>Mid-Slope Fixed Plate, Low</p> <ul style="list-style-type: none"> • 14 gauge  <p>HW-7630 (10'-0" Long) ○ HW-7631 (20'-0" Long) ○ HW-7632 (6'-0" Long) ○</p>	<p>Mid-Slope Fixed Plate, High</p> <ul style="list-style-type: none"> • 14 gauge  <p>HW-7637 (6'-0" Long) ○ HW-7638 (10'-0" Long) ○ HW-7639 (20'-0" Long) ○</p>

GENERAL INFORMATION

PRODUCT CHECKLIST

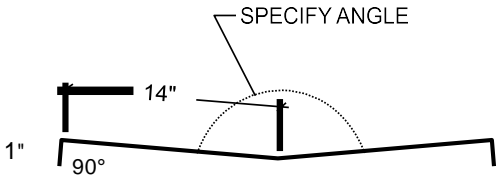
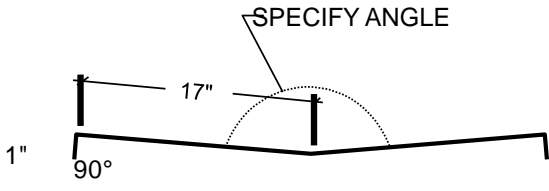
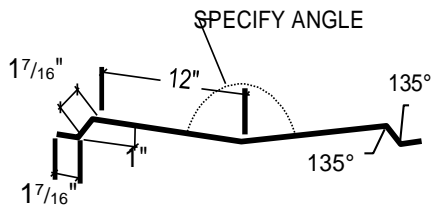
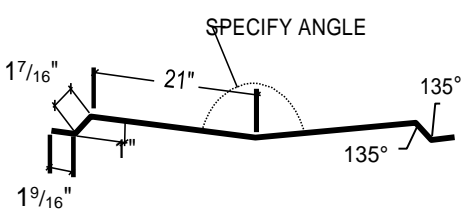
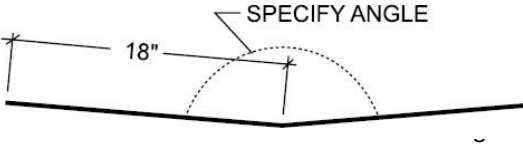
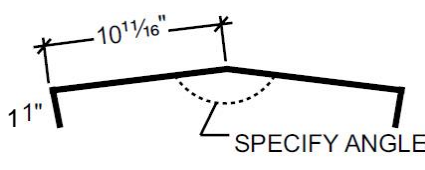
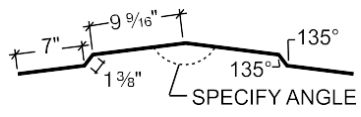
<p>Valley Support Plate – Low Systems</p>  <ul style="list-style-type: none"> • Standard Width • Use Over Purlins/Joists <p style="text-align: right;">10'-0" Long P-106 ○</p>	<p>Extended Valley Support Plate – Low Systems</p>  <ul style="list-style-type: none"> • Extended Width (Valleys Longer than 30') • Use Over Purlins/Joists <p style="text-align: right;">10'-0" Long P-101 ○</p>
<p>Valley Support Plate - High Systems</p>  <ul style="list-style-type: none"> • Standard Width • Use Over Purlins/Joists <p style="text-align: right;">10'-0" Long P-164 ○</p>	<p>Valley Support Plate – High Systems</p>  <ul style="list-style-type: none"> • Extended Width (Valleys Longer than 30') • Use Over Purlins/Joists <p style="text-align: right;">10'-0" Long P-162 ○</p>
<p>Valley Support Plate – Low Systems</p> <p style="text-align: center; font-weight: bold;">Error! Reference source not found.</p> <ul style="list-style-type: none"> • Standard Width • Use Over Rigid Insulation <p style="text-align: right;">10'-0" Long P-105 ○</p>	<p>Valley Support Plate – Low Systems</p>  <ul style="list-style-type: none"> • Extended Width (Valleys Longer than 30') • Use Over Purlins/Joists <p style="text-align: right;">10'-0" Long P-100 ○</p>
<p>Hip Support Plate - High or Low Floating Systems</p>  <ul style="list-style-type: none"> • Use Over Purlins/Joists <p style="text-align: right;">10'-0" Long P-141 ○</p>	<p>Hip Support Plate – Low Floating Systems</p> <p style="text-align: center; font-weight: bold;">Error! Reference source not found.</p> <ul style="list-style-type: none"> • Use Over Solid Substrate <p style="text-align: right;">10'-0" Long P-140 ○</p>
<p>Ridge/Hip Support Plate – Low Fixed Systems</p> <p style="text-align: center; font-weight: bold;">Error! Reference source not found.</p> <ul style="list-style-type: none"> * Use with all Substrates <p style="text-align: right;">10'-0" Long P-145 ○</p>	<p>Ridge/Hip Support Plate – High Fixed Systems</p>  <ul style="list-style-type: none"> * Use with all Substrates <p style="text-align: right;">10'-0" Long P-155 ○</p>

GENERAL INFORMATION

PRODUCT CHECKLIST

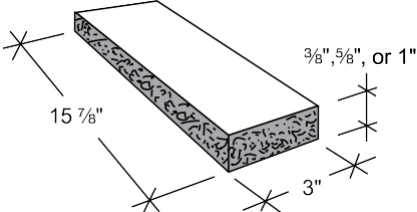
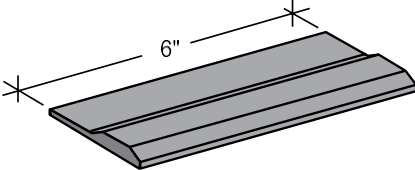
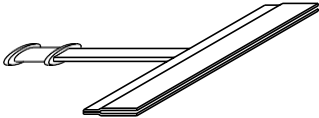
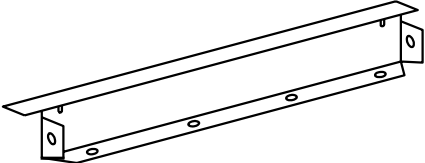
<p>Tape Sealer</p> <ul style="list-style-type: none"> • $\frac{3}{16}$" x $2\frac{1}{2}$" x 20' • For use at valley when using exposed fasteners • For use with roof curbs  <p>Triple Bead</p> <p>HW-502 ○</p> <ul style="list-style-type: none"> • $\frac{3}{16}$" x $\frac{7}{8}$" x 25' • For use at eave, ridge, endlaps and trim connections <p>HW-504 ○</p> <p>Error! Reference source not found.</p> <p>Tri-Bead</p>	<p>Thermal Spacer</p> <ul style="list-style-type: none"> • Polystyrene block used to increase the insulation capacity along the purlins  <p>HW-583 $\frac{3}{8}$" ○</p> <p>HW-582 $\frac{5}{8}$" ○</p> <p>HW-581 1" ○</p>	
<p>Tape Sealer-Swaged</p>  <p>HW-515 ○</p>	<p>Panel Hemming Tool</p>  <p>HW-602 ○</p>	<p>Tube Sealant</p> <p>Error! Reference source not found.</p> <ul style="list-style-type: none"> Urethane (White) - HW-540 ○ Urethane (Gray) - HW-541 ○ Urethane (Bronze) - HW-542 ○ Non-Skinning Butyl - HW-549 ○
<p>Outside Closure</p> <ul style="list-style-type: none"> • 24 gauge • Painted  <p>12" wide HW-446 ○</p> <p>16" wide HW-440 ○</p>	<p>Light Transmitting Panel (Reinforced) ‡</p> <p>Error! Reference source not found.</p> <ul style="list-style-type: none"> • Std. Insulated - HW-1803S ○ • Std. Uninsulated - HW-1802S ○ • UL 90 Insulated - HW-1801S ○ • UL 90 Uninsulated - HW-1800S ○ 	
<p>‡ It is the user's responsibility to ensure that the installation and use of all light transmitting panels comply with State, Federal and OSHA regulations and laws, including, but not limited to, guarding all light transmitting panels with screens, fixed standard railings, or other acceptable safety controls that prevent fall-through.</p>		

GENERAL INFORMATION

PRODUCT CHECKLIST

Ridge Flashing

PART NO.	ROOF PITCH	DIM. "A"	NOTE
FL-200	1/2 - 3 3/4:12	3 1/2"	For use without ventilator
FL-202	3 13/16-6:12	4 1/2"	18" Peak purlin spacing
FL-213	1/2 - 3 3/4:12	6 1/2"	For use without ventilator
FL-214	3 13/16-6:12	7 1/2"	24" Peak purlin spacing

Ridge Flashing

ROOF PITCH	DIM. A	NOTE	PART NO.
1/4-2 1/2:12	5 1/2"	For use without ventilator	SSRC-A
2 9/16-4:12	6 1/2"	24" Peak purlin spacing	SSRC-B
1/4-2 1/2:12	9 1/4"	For use with 9" ventilator	SSRC-C
2 9/16-4:12	10"	32" Peak purlin spacing	SSRC-D

Floating Peak Box

- Includes Cinch Angles and Flexible Membrane
- Specify Roof Slope

FL-125
Length - 2'-1"
Girth - 33 1/4"
• For use with FL-200, FL-202, FL-213, FL-214, FL-300, FL-302, FL-540 or FL-541 Ridge Flashing

FL-126
Length - 2'-6"
Girth - 37 1/4"
• For use with FL-205, FL-207, FL-303, FL-304, FL-543 or FL-544 Ridge Flashing

Ridge Flashing for Perforated Vent Drip

PART NO.	ROOF PITCH	DIM. "A"	NOTE
FL-300	1/2 - 3 3/4:12	4 1/2"	For use with perforated vent drip (FL-254)
FL-302	3 13/16 - 6:12	5 1/2"	18" Peak purlin spacing
FL-303	1/2 - 3 3/4:12	7 1/2"	For use with perforated vent drip (FL-254)
FL-304	3 13/16 - 6:12	8 1/2"	24" Peak purlin spacing

Perforated Vent Drip

- Use with FL-300, FL-302, FL-303 or FL-304 Ridge Flashing

24 Gauge Material FL-254

Ridge/Hip Flashing - Fixed

PART NO.	ROOF PITCH	DIM. "A"	NOTE
FL-209	1/2 - 3 3/4:12	6"	For use without vent material
FL-211	3 13/16-6:12	7"	18" Peak purlin spacing
FL-212	All Pitches	11 1/2"	For use without vent material

"Z" Closure

- Use at Hips

24 Gauge Material FL-361

Ridge End Cap

- Specify Ridge to be used and Roof Slope

FL-201



Sculptured High Side Eave Trim

- Specify open hem when using with continuous cleat

PART NO.	ROOF PITCH	DIM. A
FL-265	1/4-1 3/4:12	2"
FL-265B	1 13/16-4:12	3 11/16"

GENERAL INFORMATION

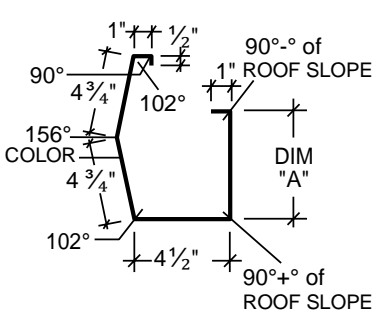
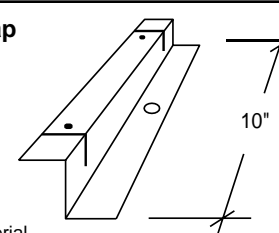
PRODUCT CHECKLIST

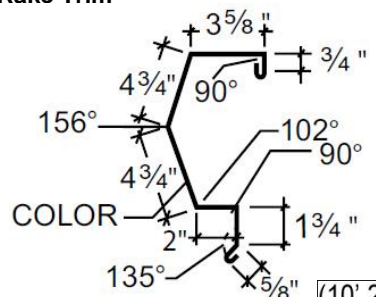
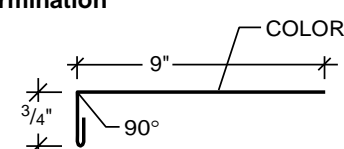
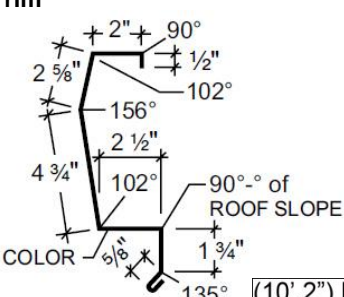
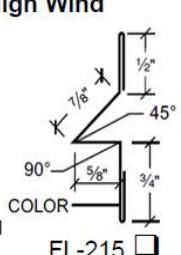
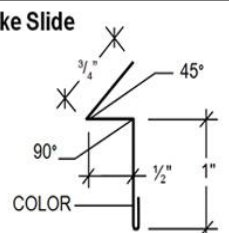
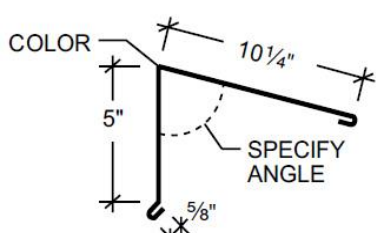
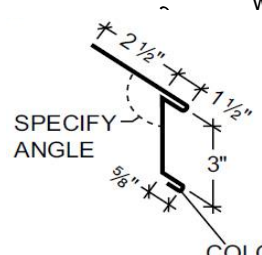
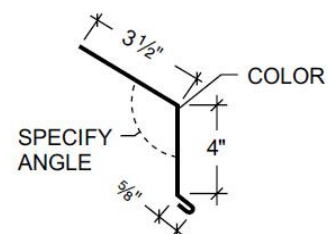
<p>Sculptured Gutter - Standard</p>  <table border="1" style="width: 100%; border-collapse: collapse; margin-top: 10px;"> <thead> <tr> <th>PART NO.</th> <th>ROOF PITCH</th> <th>DIM. "A"</th> <th>GIRTH</th> </tr> </thead> <tbody> <tr> <td>FL-248A</td> <td>1/2-4:12</td> <td>7⁵/₁₆"</td> <td>23³/₁₆"</td> </tr> <tr> <td>FL-248B</td> <td>4¹/₁₆-6:12</td> <td>7⁵/₁₆"</td> <td>24⁷/₁₆"</td> </tr> </tbody> </table>	PART NO.	ROOF PITCH	DIM. "A"	GIRTH	FL-248A	1/2-4:12	7 ⁵ / ₁₆ "	23 ³ / ₁₆ "	FL-248B	4 ¹ / ₁₆ -6:12	7 ⁵ / ₁₆ "	24 ⁷ / ₁₆ "	<p>Gutter Strap</p>  <ul style="list-style-type: none"> • For use with Sculptured Gutter <p style="text-align: right;">FL-246 ○</p> <hr/> <p>Gutter Ends Left or Right</p>  <ul style="list-style-type: none"> • Use with all Sculptured or Style Gutters • End Caps will be made to fit gutter ordered • Specify left or right • Specify gutter part number <p style="text-align: right;">FL-245 ○</p>
PART NO.	ROOF PITCH	DIM. "A"	GIRTH										
FL-248A	1/2-4:12	7 ⁵ / ₁₆ "	23 ³ / ₁₆ "										
FL-248B	4 ¹ / ₁₆ -6:12	7 ⁵ / ₁₆ "	24 ⁷ / ₁₆ "										
<p>Sculptured Rake Trim</p>  <p style="text-align: right;">(10'.2") FL-110 ○ (20'.2") FL-111 ○</p>	<p>Variable Termination</p>  <p style="text-align: right;">FL-117 ○</p>												
<p>Sculptured Eave Trim</p>  <p>Specify Roof Pitch</p> <p style="text-align: right;">(10'.2") FL-252 ○ (20'.2") FL-253 ○</p>	<p>Rake Slide - High Wind</p>  <p>Wind Load in Excess of 120 MPH 24 Gauge Material FL-215 □</p> <p>Rake Slide</p>  <p><= 120 MPH Wind Load FL-115 □</p>												
<p>Box High Side Eave Trim</p>  <p>Specify Roof Pch</p> <p style="text-align: right;">FL-331 ○</p>	<p>Eave with Extended Drip Edge</p>  <p style="text-align: right;">T-5151 ○</p> <hr/> <p>Box Eave Trim</p>  <ul style="list-style-type: none"> • Specify open hem when using with continuous cleat <p style="text-align: right;">FL-326 ○</p>												

GENERAL INFORMATION

PRODUCT CHECKLIST

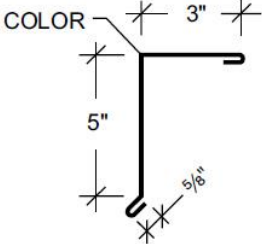
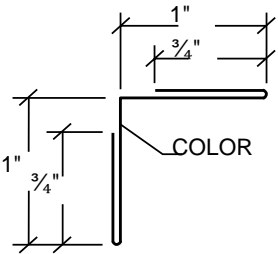
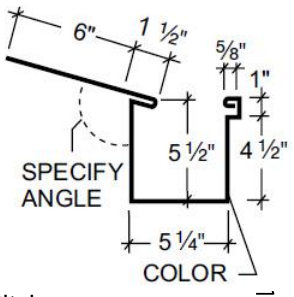
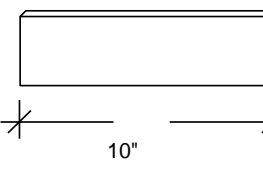
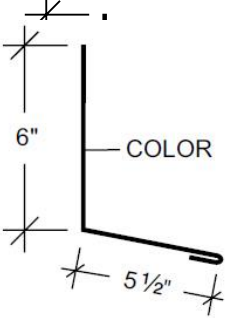
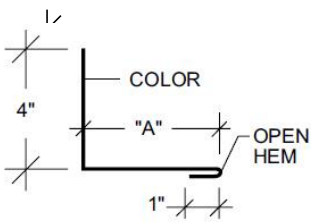
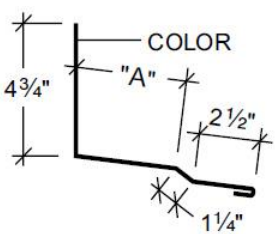
<p>Box Rake Trim</p>  <p style="text-align: right;">FL-306 ○</p>	<p>Parapet Rake Cleat - High Wind</p>  <p style="text-align: right;">F-292 ○</p>														
<p>Box Gutter with Drip Edge</p>  <p>Specify Roof Pitch</p> <p style="text-align: right;">T-5271 ○</p>	<p>Gutter Strap • For use with Box Gutter</p>  <p style="text-align: right;">FL310 ○</p>														
<p>Parapet High Side Eave Flashing - Fixed • Specify Roof Slope</p>  <p style="text-align: right;">FL-276 ○</p>	<p>Gutter Ends</p> <ul style="list-style-type: none"> • Use with T-5271 Box Gutter with Drip Edge • Specify left or right <p style="text-align: right;">T-5291 ○</p>														
<p>Parapet Rake Flash</p>  <table border="1" style="margin-left: auto; margin-right: auto; border-collapse: collapse; text-align: center;"> <thead> <tr> <th>PART NO.</th> <th>DIM. A</th> </tr> </thead> <tbody> <tr> <td>FL-285</td> <td>3" ○</td> </tr> <tr> <td>FL-286</td> <td>5" ○</td> </tr> <tr> <td>FL-287</td> <td>7" ○</td> </tr> </tbody> </table>	PART NO.	DIM. A	FL-285	3" ○	FL-286	5" ○	FL-287	7" ○	<p>Parapet High Side Eave Flash - Floating</p>  <table border="1" style="margin-left: auto; margin-right: auto; border-collapse: collapse; text-align: center;"> <thead> <tr> <th>PART NO.</th> <th>DIM. A</th> </tr> </thead> <tbody> <tr> <td>FL-275</td> <td>3 1/2" ○</td> </tr> <tr> <td>FL-274</td> <td>4 1/2" ○</td> </tr> </tbody> </table>	PART NO.	DIM. A	FL-275	3 1/2" ○	FL-274	4 1/2" ○
PART NO.	DIM. A														
FL-285	3" ○														
FL-286	5" ○														
FL-287	7" ○														
PART NO.	DIM. A														
FL-275	3 1/2" ○														
FL-274	4 1/2" ○														

NOTE: All trim to be 26 gauge material unless noted. Refer to current price book for part numbers and descriptions.

GENERAL INFORMATION

PRODUCT CHECKLIST

SUBJECT TO CHANGE WITHOUT NOTICE

SEE www.vulcansteel.com FOR CURRENT INFORMATION

SL-15

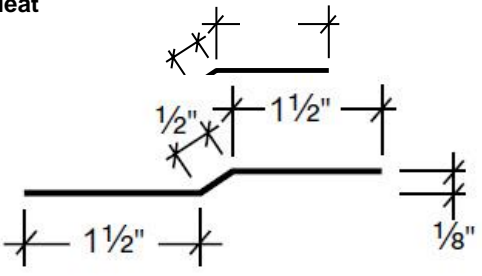
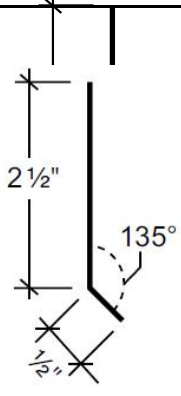
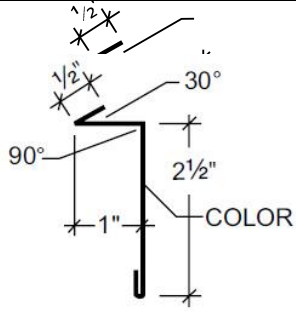
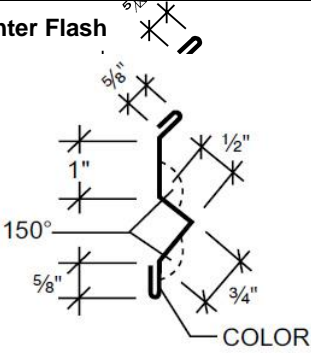
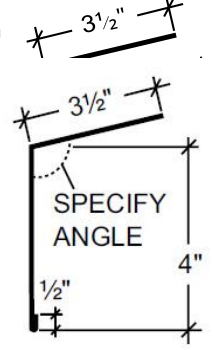
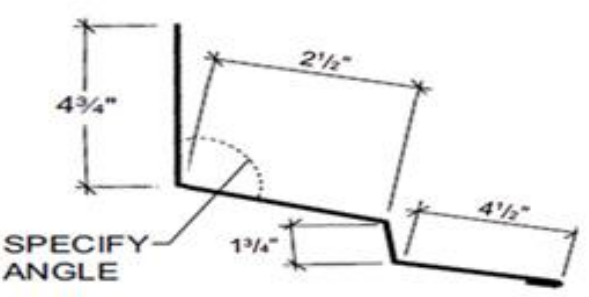
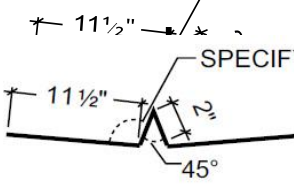
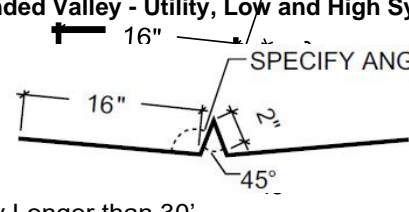
<p>Offset Cleat</p>  <p>24 Gauge Material</p> <p>Offset found</p> <p>1/8" FL-337 ○</p>	<p>Continuous Cleat</p>  <p>24 Gauge Material</p> <p>FL-338 ○</p>
<p>Counter Flash</p>  <p>24 Gauge Material</p> <p>FL-341 ○</p>	<p>Alternate Counter Flash</p>  <p>24 Gauge Material</p> <p>FL-343 ○</p>
<p>Box Panel Cap Trim</p>  <p>Specify Roof Pitch</p> <p>FL-272 ○</p>	<p>Parapet High Side Flash</p>  <p>SSPT</p>
<p>Standard Valley - Utility, Low and High Systems</p>  <p>24 Gauge Material</p> <p>FL-705 ○</p>	<p>Extended Valley - Utility, Low and High Systems</p>  <p>Valley Longer than 30'</p> <p>24 Gauge Material</p> <p>FL-711 ○</p>

GENERAL INFORMATION

PRODUCT CHECKLIST

SL-16

SEE www.vulcansteel.com FOR CURRENT INFORMATION

SUBJECT TO CHANGE WITHOUT NOTICE

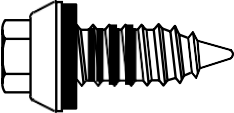
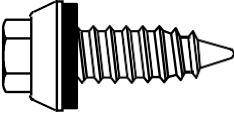
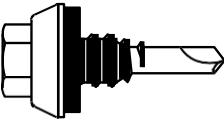
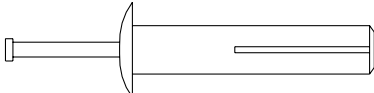
<p>Fastener #1B</p> <ul style="list-style-type: none"> • Clip to purlin (Up to 4" insulation between panel and purlin) <p style="text-align: center; font-weight: bold; margin-top: 20px;">Error! Reference source not found.</p> <p style="font-size: small; margin-top: 20px;">1/4"-14 x 1 1/4" Self Driller 5/16" Hex Washer Head with no washer ○</p>	<p>Fastener #1E</p>  <ul style="list-style-type: none"> • Panel to eave plate or eave strut • Rake trim to roof panel • Standard endlaps • Panel to valley plate • Outside closure to panel with back-up plate or support plate <p style="font-size: small; margin-top: 10px;">1/4"-14 x 1 1/4" Long Life Self Driller 5/16" Hex Washer Head, with sealing washer ○</p>
<p>Fastener #1F</p> <ul style="list-style-type: none"> • Clip to purlin (Over 4" insulation between panel and purlin) <p style="text-align: center; font-weight: bold; margin-top: 20px;">Error! Reference source not found.</p> <p style="font-size: small; margin-top: 20px;">1/4"-14 x 1 1/2" Self Driller 5/16" Hex Washer Head with no washer ○</p>	<p>Fastener #2A</p>  <ul style="list-style-type: none"> • Use in place of Fasteners #1E, #2B and #4 at all strip outs <p style="font-size: small; margin-top: 10px;">17 x 1" Long Life AB 5/16" Hex Washer Head, with sealing washer ○</p>
<p>Fastener #2B</p> <ul style="list-style-type: none"> • Endlap over plywood  <p style="font-size: small; margin-top: 10px;">1/4"-14 x 1" Long Life AB 3/8 Hex Washer Head, with sealing washer ○</p>	<p>Fastener #6A</p> <ul style="list-style-type: none"> • Clip to joist <p style="text-align: center; font-weight: bold; margin-top: 20px;">Error! Reference source not found.</p> <p style="font-size: small; margin-top: 20px;">12-24 x 1 1/4" Tek® 5 Self Driller 5/16" Hex Washer Head, with no washer ○</p>
<p>Fastener #5</p> <ul style="list-style-type: none"> • Rake support to purlin (Floating System Only) • Floating eave plate to eave strut <p style="text-align: center; font-weight: bold; margin-top: 20px;">Error! Reference source not found.</p>	<p>Fastener #4</p>  <ul style="list-style-type: none"> • Ridge and other flashing to outside closure • Gutter to panel • Gutter to strap • Trim to trim connections • Sculptured eave trim to panel <p style="font-size: small; margin-top: 10px;">1/4"-14 x 7/8" Long Life Lap Tek® Self Driller 5/16" Hex Washer Head, with sealing washer ○</p>
<p>Fastener #11</p>  <ul style="list-style-type: none"> • Special application fastener • For attaching trim to masonry walls 	

GENERAL INFORMATION

PRODUCT CHECKLIST

1/4"-14 x 1 1/4" Shoulder Tek® 2 Self Driller
5/16" Hex Washer Head, with no washer



1/4" x 1 1/4" Nail Drive Masonry Anchor







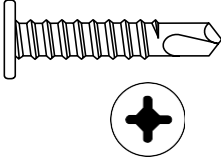

SUBJECT TO CHANGE WITHOUT NOTICE

SEE www.vulcansteel.com FOR CURRENT INFORMATION

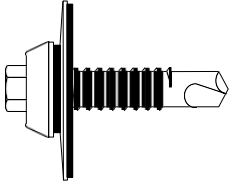
SL-17

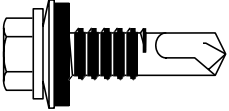
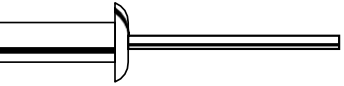
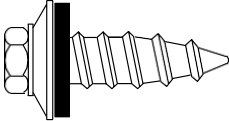
GENERAL INFORMATION

<p>Fastener #12A</p> <ul style="list-style-type: none"> • Rake angle to purlin • Hip and valley support plates to purlins • Valley flashing to valley support plate  <p>12 x 1" #2 Phillips/Square Drive Pancake Head Driller ○</p>	<p>Fastener #13A</p> <ul style="list-style-type: none"> • Offset cleat to plywood • Rake angle to plywood <p>Error! Reference source not found.</p>  <p>12 x 1" #2 Phillips/Square Drive Pancake Type "A" ○</p>
<p>Fastener #14A</p> <ul style="list-style-type: none"> • Outside closure to angle on floating hip detail <p>Error! Reference source not found.</p> <p>Stainless Steel Pop Rivet 1/8" diameter x 3/8" grip range ○</p>	<p>Fastener #43L</p> <ul style="list-style-type: none"> • Use at lower endlap of LTP's  <p>1/4"-14 x 7/8" Long Life Lap TEK 5/16" Hex Head, with 1 1/8" O.D. washer ○</p>
<p>Fastener #14</p> <ul style="list-style-type: none"> • Trim to trim connections  <p>Stainless Steel Pop Rivet 1/8" diameter x 3/16" grip range ○</p>	<p>Fastener #1</p> <ul style="list-style-type: none"> • Eave plate to eave strut • Mid-slope fixed plate to purlin • Rake support to angle (Fixed system only)  <p>1/4"-14 x 1" Self Driller 5/16" Hex Head, with 5/8" O.D. washer ○</p>
<p>Fastener #226</p> <ul style="list-style-type: none"> • Dekstrip to Expansion Ridge/Expansion Lap  <p>3/16" x 9/16" Rivet Cendalum Closed End Rivet ○</p>	<p>Fastener #46</p> <ul style="list-style-type: none"> • Panel endlaps over solid substrate <p>Error! Reference source not found.</p> <p>1/4"-14 x 5/8" Long Life Type B with washer ○</p>
<p>Fastener #18</p> <ul style="list-style-type: none"> • Panel clips to wood deck • Outside closure to panel over wood deck  <p>14 x 1" Type A 5/16" Hex Washer Head, with 5/8" O.D. washer ○</p>	<p>Deck Screw</p> <ul style="list-style-type: none"> • 18 Gauge maximum drilling thickness  <p>Fastener #209 14 x 2" ○ Fastener #210 14 x 3" ○ Fastener #211 14 x 4" ○ Fastener #15D 14 x 6" ○</p>
<p>Fastener #228</p> <ul style="list-style-type: none"> • Dekstrip to Expansion Ridge/Expansion Lap <p>Error! Reference source not found.</p> <p>10 x 1/2" Aluminum Grommet Washer ○</p>	

GENERAL INFORMATION

SL216®

Panel Orientation

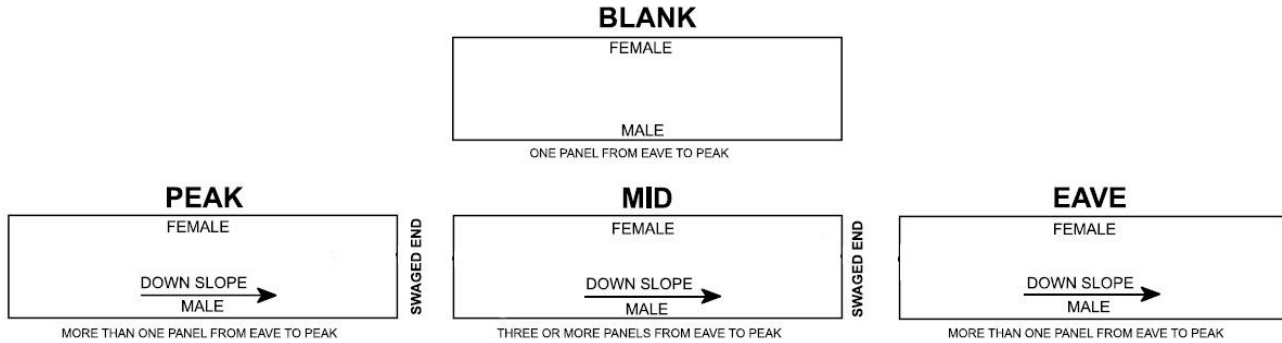

INSTALLATION GUIDELINES

- I. Jobsite Storage and Handling
 - A. Check the shipment against the shipping list.
 - B. Damaged material must be noted on Bill of Lading.
 - C. Panel crates should be handled carefully. A spreader bar of appropriate length is recommended for hoisting.
 - D. Check to see that moisture has not formed inside the bundles during shipment. If moisture is present, panels should be uncrated and wiped dry, then restacked and loosely covered so that air can circulate between the panels.
- II. Application Checklist
 - A. Check substructure for proper alignment and uniformity to avoid panel distortion.
 - B. Periodic check of panel alignment is crucial to proper panel alignment.
 - C. If there is a conflict between this manual and the project erection drawings, the erection drawings will take precedence.
- III. LTP Warning
 - A. **WARNING: Light transmitting panels are not designed or intended to bear the weight of any person walking, stepping, standing or resting on them. THE MANUFACTURER DISCLAIMS ANY WARRANTY OR REPRESENTATION, EXPRESS OR IMPLIED, that any person can safely walk, step, stand or rest on or near these light transmitting panels or that they comply with any OSHA regulation.**



**SHEETING DIRECTION FOR
ROOFS WITHOUT PANEL
ENDLAPS**

**SHEETING DIRECTION FOR
ROOFS WITH PANEL
ENDLAPS**

GENERAL INFORMATION

PREPARATORY REQUIREMENTS

1. For the purpose of this manual, we have assumed that the **SL216®** roof will be installed over purlins and an eave gutter will be installed. Please refer to the Design Section of the manuals for details of **SL216®** over other substrates.
2. A rake angle or an alternate structural flat surface must be installed on top of the purlins to accept the rake support.
3. All primary and secondary framing must be erected, plumbed and squared with bolts tightened according to accepted building practices.
4. The substructure (eave to ridge) must be on plane ($1/4"$ in 20' or $3/8"$ in 40' tolerance).
5. It is critical that the purlins or bar joists at the ridge and endlaps be located exactly as detailed and that they are straight from rafter to rafter. Any mislocation or bowing of these members can cause the fasteners at the ridge or endlaps to foul as the panels expand and contract.
6. The manufacturer recommends the use of a screw gun with a speed range of 0-2000 RPM to properly install all fasteners referenced in this manual. Tools rated to 4000 RPM should never be used for self drilling fasteners typically supplied with metal roof and wall systems.
7. Field cutting of the panels should be avoided where possible. If field cutting is required, the panels must be cut with nibblers, snips, or shears to prevent edge rusting. Do not cut the panels with abrasive saw blades, grinders, or torches.

CAUTION

Avoid restricting the thermal expansion and contraction of the **SL216®** panels.
(i.e., Do not attach panel to the substructure at either the eave and ridge.)

WARNING: Light transmitting panels are not designed or intended to bear the weight of any person walking, stepping, standing or resting on them. THE MANUFACTURER DISCLAIMS ANY WARRANTY OR REPRESENTATION, EXPRESS OR IMPLIED, that any person can safely walk, step, stand or rest on or near these light transmitting panels or that they

NOTE

It is the responsibility of the erector to install this roof using safe construction practices that are in compliance with OSHA regulations. The manufacturer is not responsible for the performance of this roof system if it is not installed in accordance with the instructions shown in this manual. Deviations from these instructions and details must be approved in writing by the manufacturer.

Error! Reference source not found.

GENERAL INFORMATION

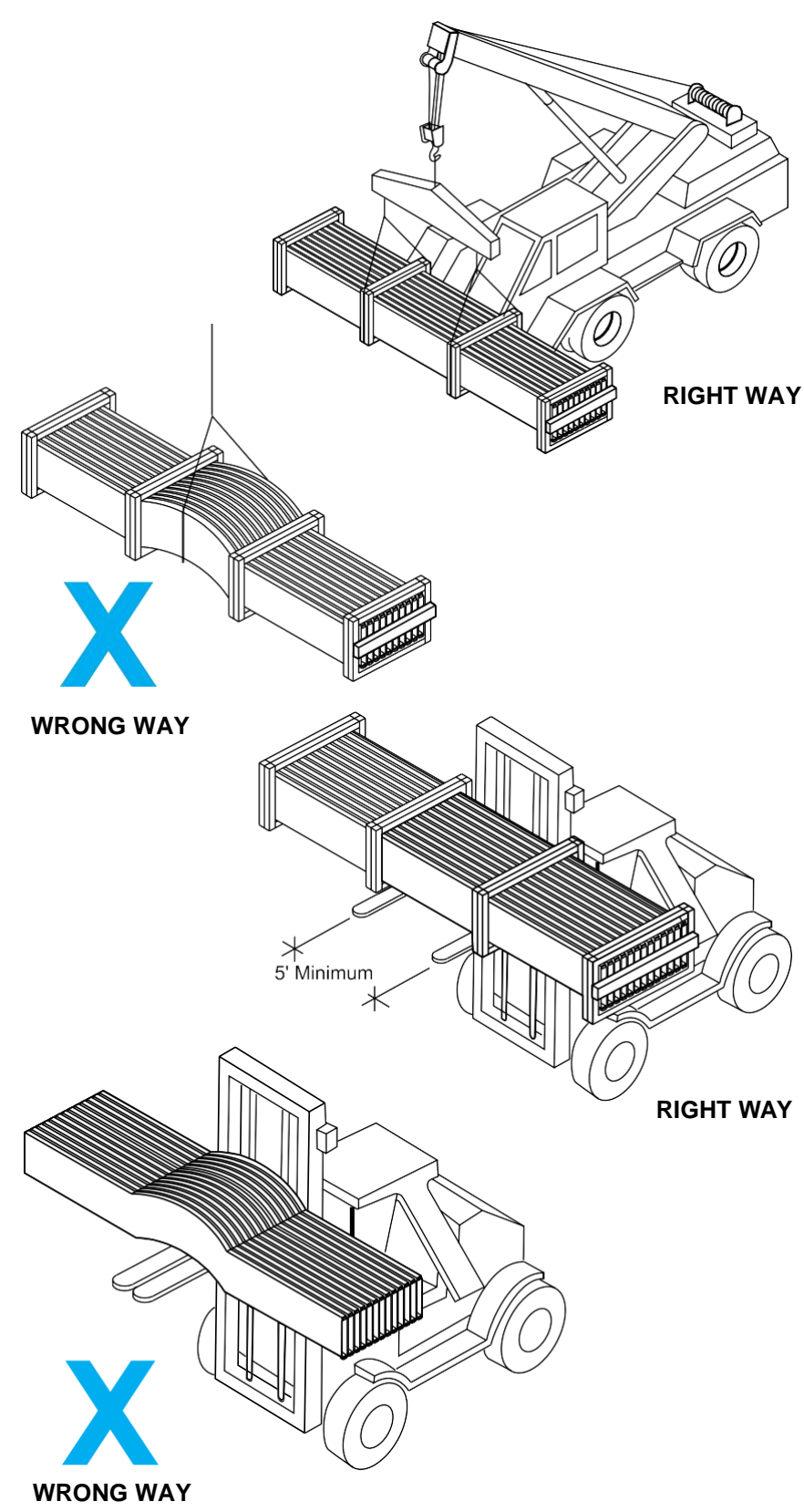

UNLOADING

Upon receiving material, check shipment against shipping list for shortages and damages. The manufacturer will not be responsible for shortages or damages unless they are noted on the shipping list.

Each bundle should be lifted at its center of gravity. Where possible, bundles should remain banded until final placement on roof. If bundles must be opened, they should be retied before lifting.

When lifting bundles with a crane, a spreader bar and nylon straps should be used. **NEVER USE WIRE ROPE SLINGS, THEY WILL DAMAGE THE PANELS.**

When lifting bundles with a forklift, forks must be a minimum of five feet apart. Do not transport open bundles. Drive slowly when crossing rough terrain to prevent panel buckling.

CAUTION
Improper unloading and handling of bundles and crates may cause bodily injury or material damage. The manufacturer is not responsible for bodily injuries or material damages during unloading and storage.

GENERAL INFORMATION

UNLOADING (Continued)

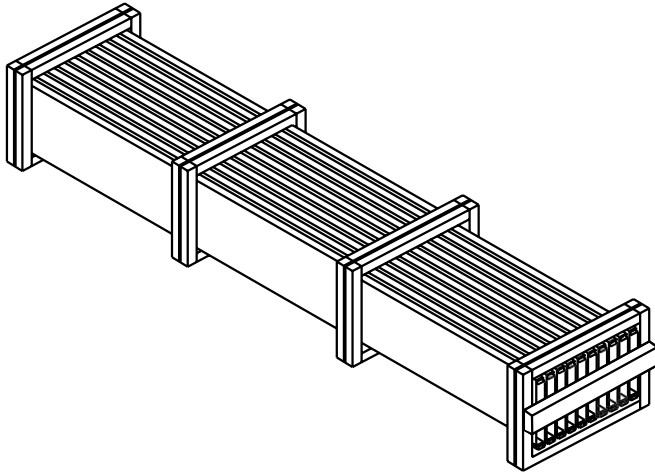

BLOCK AND BAND

This method of bundling is used for orders that are to be picked up by the customer or shipped by common carrier. 2 x 4's are strapped under the bundles to allow access for straps or a forklift. Bundles less than 25' long may be handled by a forklift. The forklift should have at least 5' between forks. Bundles longer than 25' should be lifted utilizing a spreader bar with nylon straps.

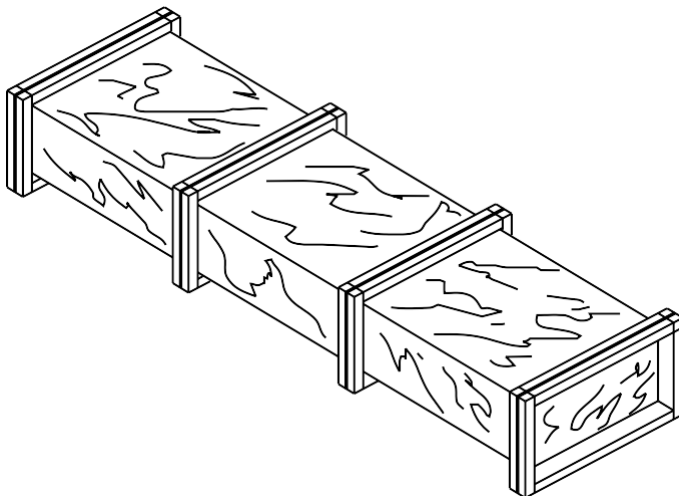

FULL CRATE

This method is used on all overseas shipments or by customer's order. Handling requirements are the same as block and band.

GENERAL INFORMATION

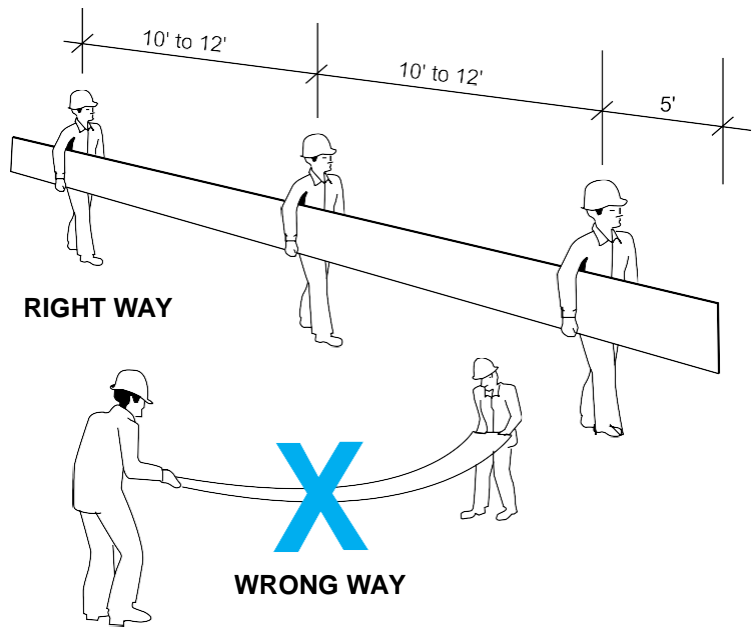

HANDLING/PANEL STORAGE

Standing on one side of the panel, lift it by the seam. If the panel is over 10' long, lift it with two or more people on one side of the panel to prevent buckling.

Do not pick panels up by the ends.

NOTE:
Protective gloves and safety glasses should always be used while handling panels. OSHA safety regulations must be followed at all times.

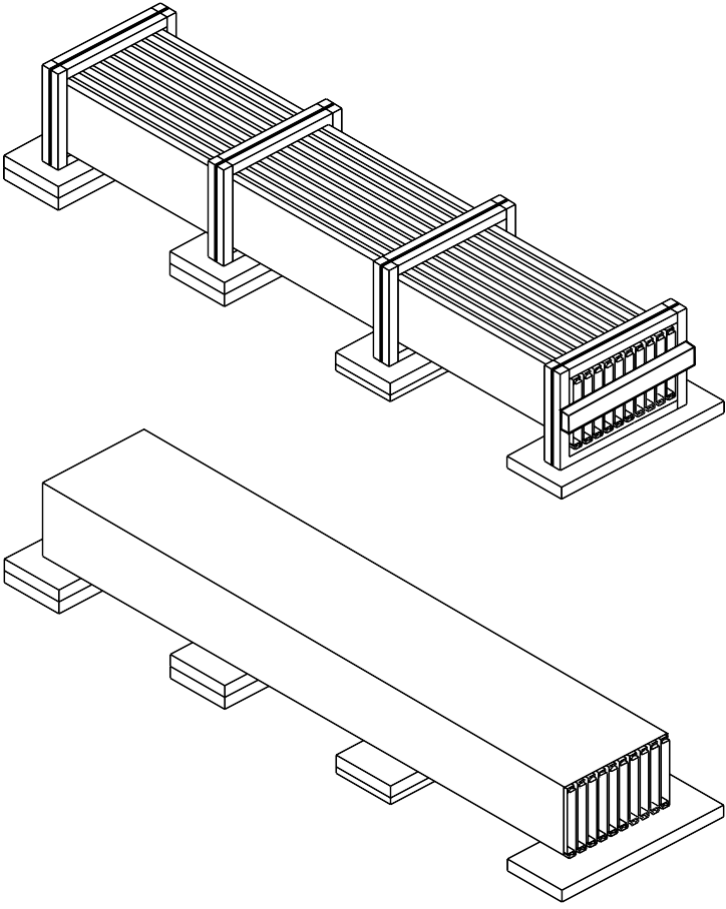

Store bundled sheets off the ground sufficiently high to allow air circulation beneath bundle and to prevent rising water from entering bundle. Slightly elevate one end of bundle. Prevent rain from entering bundle by covering with tarpaulin, making provision for air circulation between draped edges of tarpaulin and the ground. **PROLONGED STORAGE OF SHEETS IN A BUNDLE IS NOT RECOMMENDED.** If conditions do not permit immediate erection, extra care should be taken to protect sheets from white rust or water marks.

Check to see that moisture has not formed inside the bundles during shipment. If moisture is present, panels should be uncrated and wiped dry, then restacked and loosely covered so that air can circulate between the panels.

GENERAL INFORMATION

PROPER HANDLING, STORAGE AND MAINTENANCE OF PAINTED AND GALVALUME PLUS® PANELS

PANEL HANDLING

- All panel bundles must be inspected during unloading and carrier advised immediately if damage is noted.
- Never unload or move panel bundles that have been opened without adequately clamping them. Without the banding to hold the bundle stable, panels may shift during unloading or movement, causing the bundle to fall.
- Never use wire slings to unload or move panel bundles.
- When unloading or moving panel bundles over 20' long, a spreader bar may be required. It is the erector's responsibility to determine the location and number of lift points required to safely unload or move panel bundles.
- When handling individual panels, always wear protective gloves. OSHA safety regulations must be followed at all times.
- When cutting panels, always wear all required safety equipment such as safety glasses and gloves. Cut panels with nibblers, shears or snips. Do not use abrasive blade saws as these will melt the Galvalume® coating causing the panel to edge rust which will void the Galvalume® and Paint warranties. Drilling fasteners into panels will create metal filings that will rust and create an unsightly stain. Metal filings must be removed by sweeping or wiping down panels immediately after installation to avoid this occurrence.

PANEL STORAGE

- If water is permitted to enter panel bundles, it is necessary to open bundles, separate the panels and dry all surfaces.
- Store bundled panels off the ground sufficiently high to allow air circulation beneath bundle and to prevent rising water from entering bundle. Slightly elevate one end of bundle.
- Prevent rain from entering bundle by covering with tarpaulin, making provision for air circulation between draped edges of tarpaulin and the ground.
- Prolonged storage of panels in a bundle is not recommended. If conditions do not permit immediate erection, extra care should be taken to protect panels from white rust or water marks. If panels have not been erected within three weeks of receipt, the panels should be removed from the bundle for inspection. Condensation may cause damage to panels. The manufacturer's Paint and Galvalume® warranties do not cover damage caused by improper panel storage.

PANEL MAINTENANCE

- Never allow Galvalume® panels to come into contact with or water runoff from dissimilar materials such as copper, lead, or graphite. These materials will cause galvanic corrosion of the panels and will void the Galvalume® warranty. This includes treated wood and AC condensate, both of which contain copper compounds. This also applies to painted panels.
- Always use long life fasteners in all exposed fastener applications. Non long life fasteners can rust through the panel at each exposed fastener location. Use of non long life fasteners in exposed applications will void the Galvalume® and Paint warranties.
- Panels should be protected against exposure to masonry products, strong acids or bases and solvents. Exposure to these agents may etch or stain Galvalume Plus® panels and cause painted panels to blister or peel.
- Never allow anyone to apply any coating or patching material to the panel surface. These products may contain chemicals that will adversely affect the Galvalume Plus® or paint coating. Also, water may become trapped between the coating material and the panel, causing premature corrosion.

If you have any question as to proper methods to use in the handling, storage or maintenance of these panels, call your nearest manufacturer representative.

GENERAL INFORMATION

- Never allow anyone to apply any coating or patching material to the panel surface. These products may contain chemicals that will adversely affect the Galvalume Plus® or paint coating. Also, water may become trapped between the coating material and the panel, causing premature corrosion.

If you have any question as to proper methods to use in the handling, storage or maintenance of these panels, call your nearest manufacturer representative.

NOTICE

Uniform visual appearance of Galvalume Plus® coated panels cannot be guaranteed. The Galvalume Plus® coating is subject to variances in spangle from coil to coil which may result in a noticeable shade variation in installed panels. The Galvalume Plus® coating is also subject to differential weathering after panel installation. Panels may appear to be different shades due to this weathering characteristic. If uniform visual appearance is required, the manufacturer recommends that our prepainted Standard Color or KANAR panels be used in lieu of Galvalume Plus®. Shade variations in panels manufactured from Galvalume Plus® coated material do not diminish the structural integrity of the product. These shade variations should be anticipated and are not a cause for rejection.

INSTALLATION SEQUENCE

STEP 1

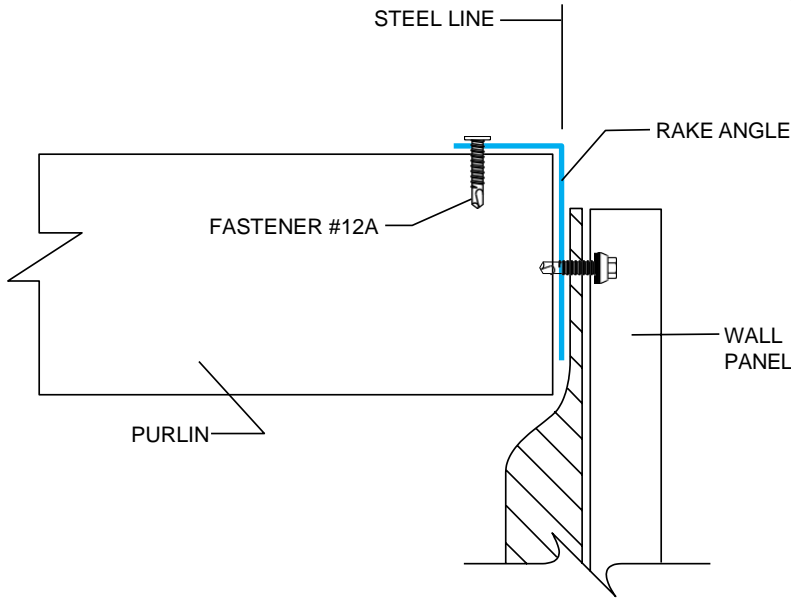
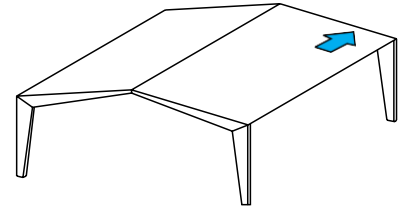

RAKE ANGLE ATTACHMENT

RAKE ATTACHMENT

Attach the rake angle to the purlin with the Fastener #12A.

Attach the rake support on top of the rake angle with the proper self-drilling fasteners (See "Rake Support Fastener Requirements" Below) on 2'-0" centers with a fastener in the first and last prepunched slot. The vertical leg is to be installed flush with the steel line.

IT IS IMPORTANT THAT THE RAKE SUPPORT IS INSTALLED STRAIGHT AND SQUARE WITH THE EAVE AS IT CONTROLS THE ALIGNMENT OF THE ROOF SYSTEM.

Install 6" long pieces of double faced tape (not by Manufacturer) on 3'-0" centers to the top of the horizontal leg of the rake support. This will help hold the insulation in place at the rake.

**RAKE SUPPORT
FASTENER REQUIREMENTS**

- Fixed System - Fastener #1
- Floating System - Fastener #5

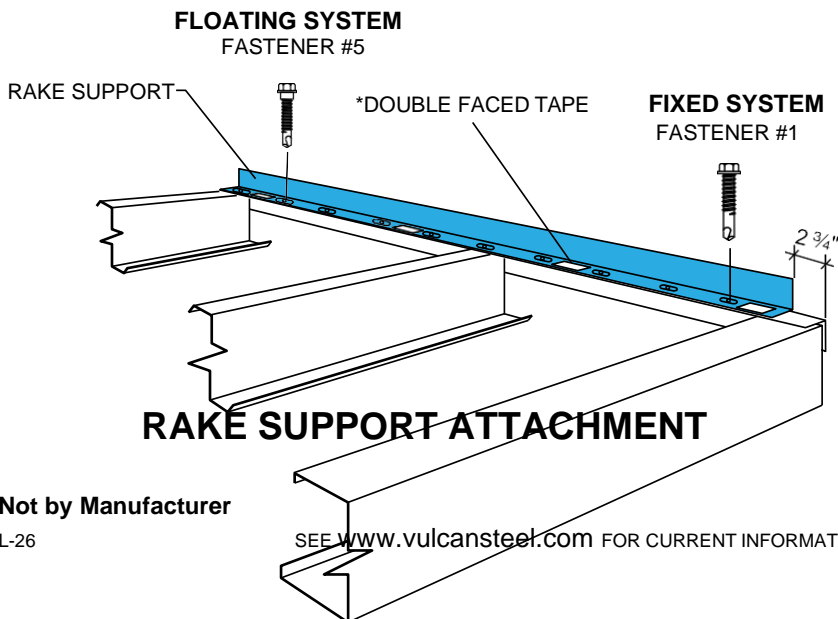

RAKE SUPPORT ATTACHMENT

*Not by Manufacturer
SL-26

SEE [WWW.VULCANSTEEL.COM](http://www.vulcansteel.com) FOR CURRENT INFORMATION

Error! Reference source not found.

SUBJECT TO CHANGE WITHOUT NOTICE

INSTALLATION SEQUENCE

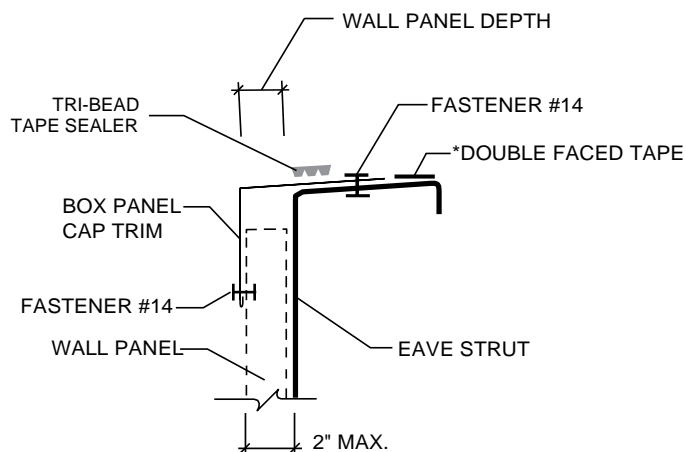

WALL PANEL INSTALLED BEFORE ROOF

STEP 2

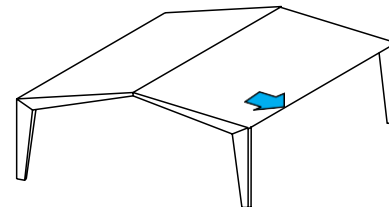

LOW SYSTEM EAVE

For applications in which the wall panels have already been erected, install box panel cap trim or offset panel cap trim to the eave strut with Fastener #14. Eave trim must be pulled tight to wall panels with Fastener #14 before fastening to eave strut

Install Tri-Bead tape sealer along top of the trim.

For vinyl insulation, install double faced tape (not by Manufacturer) along the length of the top leg of the trim. Double faced tape must be upslope from Tri-Bead tape sealer.

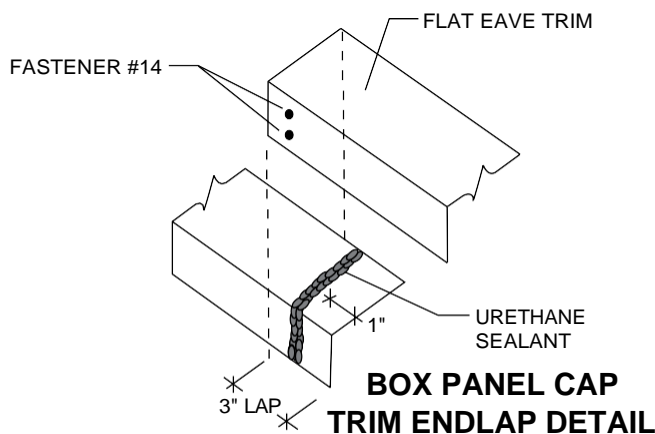

Lap trim 3". Apply two beads of urethane sealant between the trim pieces, approximately 1" from the end of the bottom piece. Attach trim laps in flat eave trim with Fastener #14. Attach trim laps on panel cap trim with Fastener #4.

*Not by Manufacturer

INSTALLATION SEQUENCE

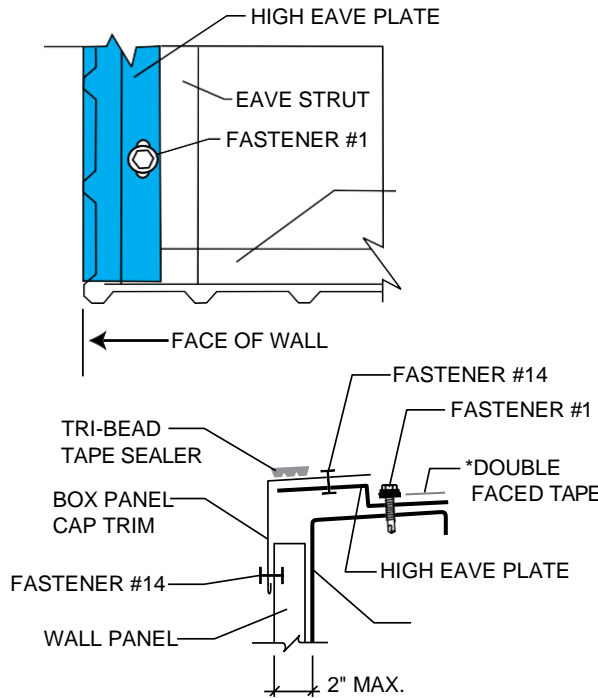

**FLAT EAVE TRIM DETAIL
(WITHOUT GUTTER)**

**STEP
2A**

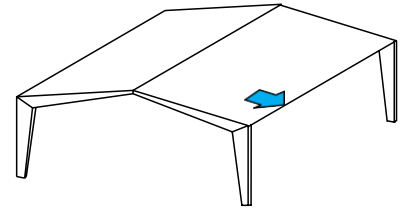

HIGH SYSTEM EAVE

Wall Panels Installed Before Roof

Install high eave plates flush with the outside face of the high crowns of the wall panels. Install Fastener #1 in prepunched slots (1'-0" on center) of the eave plate. The first eave plate will butt against the rake support. All of the eave plates may be installed at this time.

Be sure to butt each eave plate end to end without leaving a gap between the plates. Place an 8" length of Triple Bead tape sealer at each butt joint.

Install box panel cap trim to the top of the eave plates. Check to make sure the trim is flat against the wall. Attach the trim to the eave plate and the wall panel with a Fastener #14 at 10'-0" centers.

Lay Tri-Bead tape sealer across the top of the eave trim, flush with the outside edge.

For vinyl back insulation, install double faced tape (not by manufacturer) along the length of the bottom of the eave plate. Double faced tape must be upslope from the Tri-Bead tape sealer.

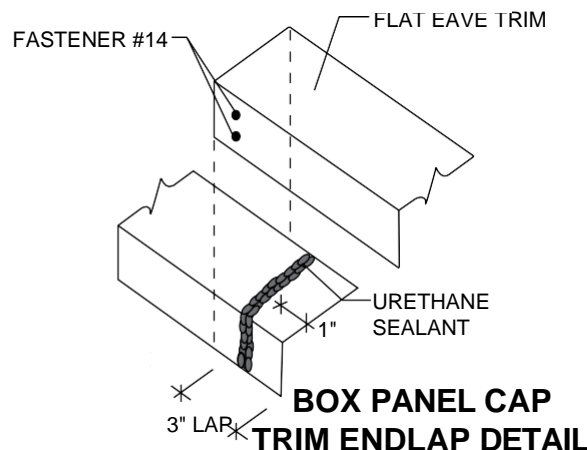

**BOX PANEL CAP
TRIM ENDLAP DETAIL**

Lap trim 3". Apply two beads of urethane sealant between the trim pieces, approximately 1" from the end of the bottom piece. Attach trim laps in flat eave trim with Fastener #14. Attach trim laps on panel cap trim with Fastener #4.

INSTALLATION SEQUENCE

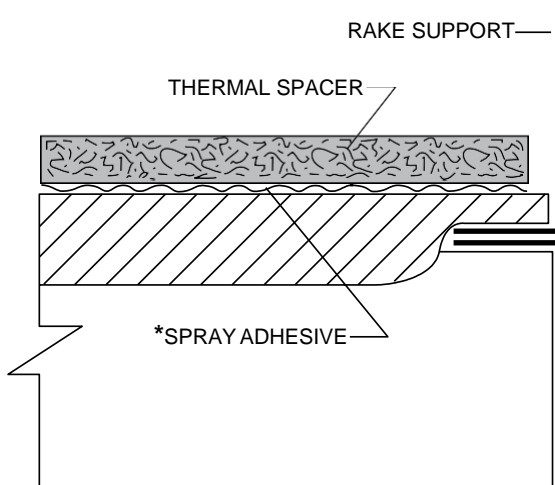
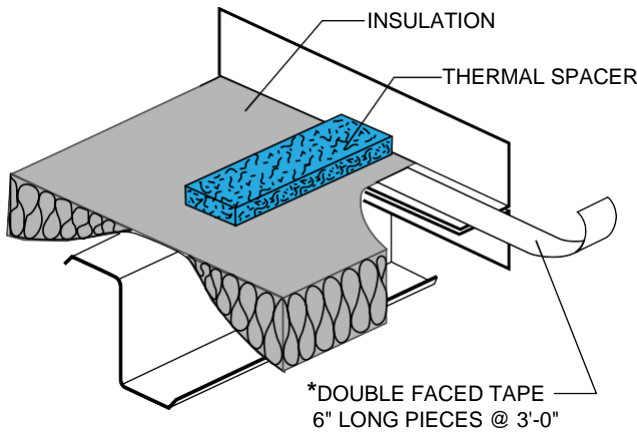
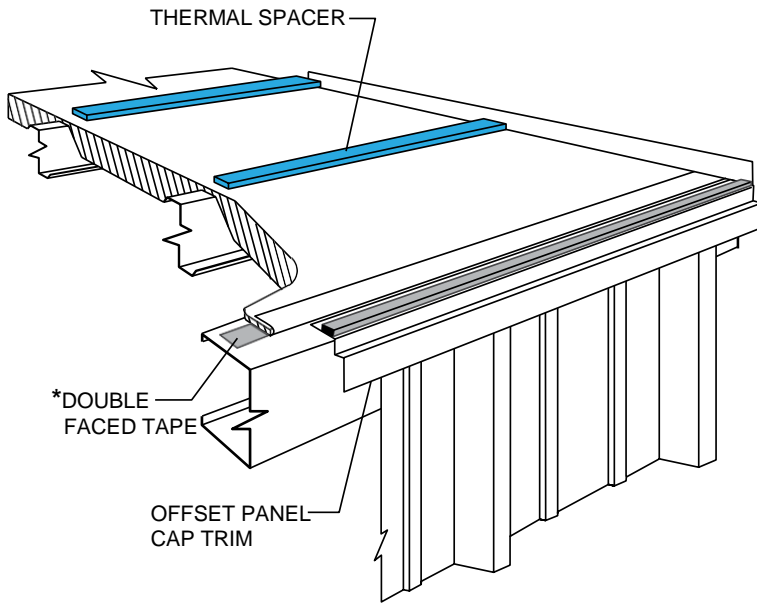

STEP 3

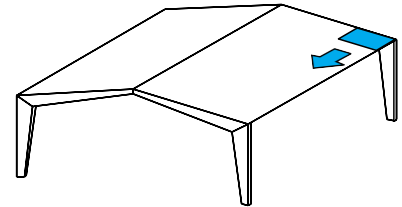

THERMAL SPACER (FOR HIGH SYSTEM ONLY)

Position the thermal spacer on top of the insulation over each purlin and against the rake support prior to installing the roof panel.

Using spray adhesive, (not by manufacturer), adhere the thermal spacer to the insulation (First Panel Run Only). The thermal spacer increases the insulation capacity along the purlins.

*Not by manufacturer

SUBJECT TO CHANGE WITHOUT NOTICE

SEE www.vulcansteel.com FOR CURRENT INFORMATION

SL-29

INSTALLATION SEQUENCE

STEP 4

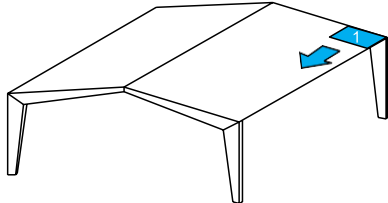

FIRST PANEL

Position the panel so that it overhangs the eave strut by the dimension shown on the building drawings. The upper end of the panel must extend 7" beyond the web of the purlin if the panel covers eave to ridge. If more than one panel is required to cover eave to ridge, one or more endlaps will be required. The upper end of the panel will extend 10" beyond the web of the purlin at endlaps.

NOTE:
If an endlap is required then roof panel must be sheeted right to left as viewed from the eave looking toward the ridge.

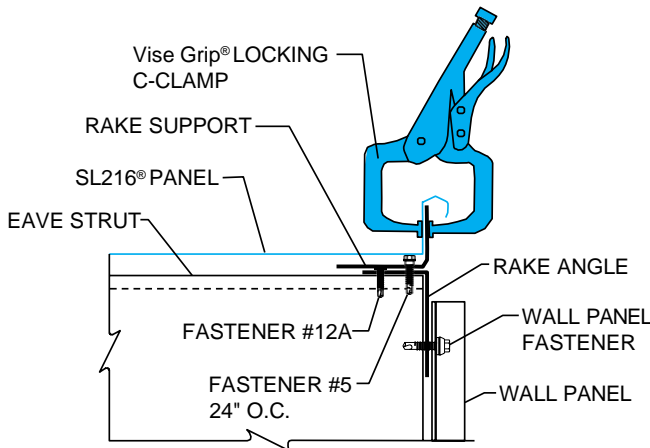
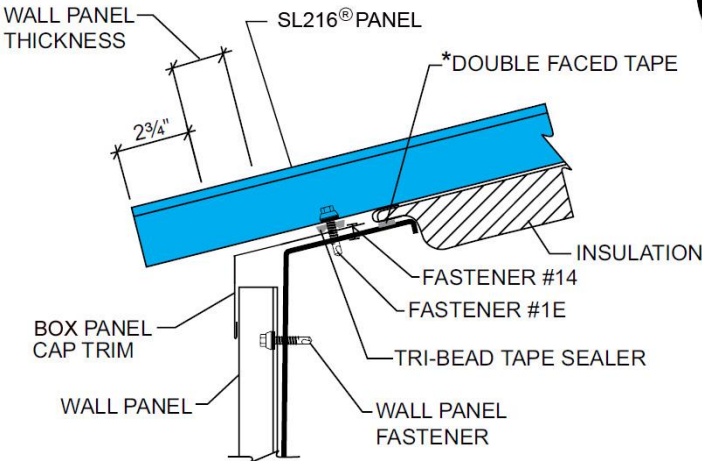

Lay the female leg of the panel over the rake support. To prevent wind damage, secure the female leg of the panel to the rake support with Vise Grip® Locking C-Clamps or temporary fasteners. Fasteners must go through the rake support. The panel will not be fastened permanently to the rake support until the rake trim is installed.

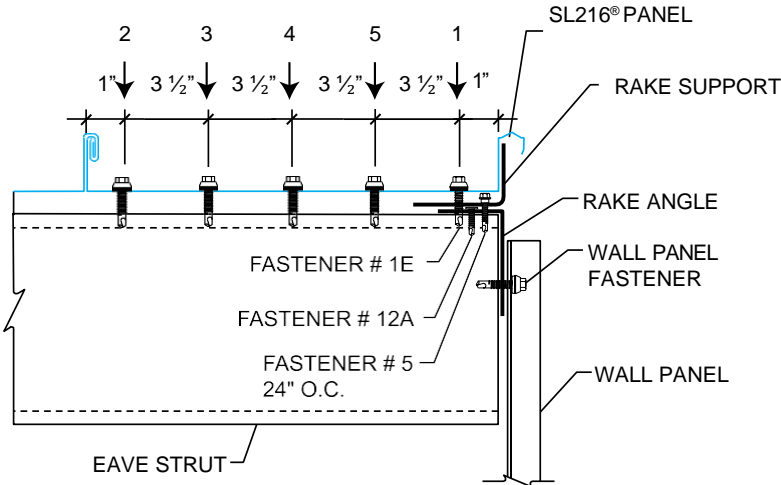

FASTENING PATTERN AT EAVE

Attach the panel to the eave strut or eave plate with Fastener #1E. Five fasteners are required at this location.

*Not by Manufacturer

INSTALLATION SEQUENCE

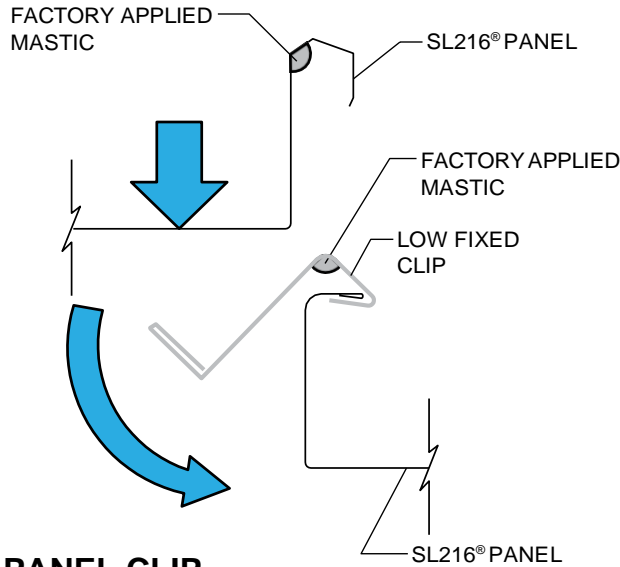

PANEL CLIP INSTALLATION

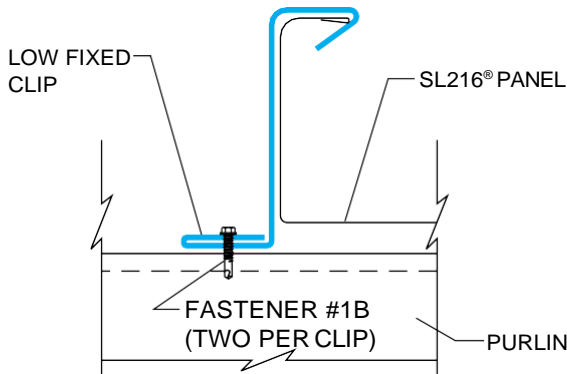

RIGHT WAY

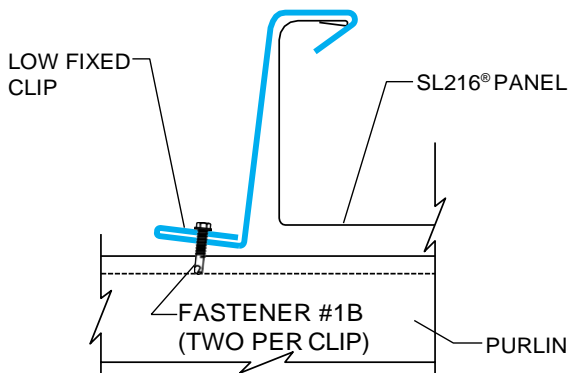

WRONG WAY

STEP 5

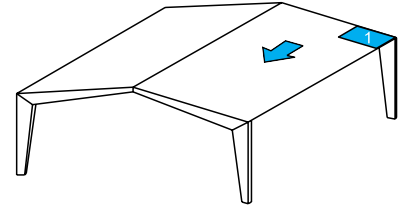

CLIP INSTALLATION

Hook the panel clip onto male leg of panel. Hold end of clip up to keep it engaged onto male leg and rotate the clip base down to completely engage clip onto male leg. Install panel clips at each purlin.

Before fastening clip to purlins, check to ensure that vertical leg of clip is tight to the vertical leg of the panel. Failure to keep this leg tight to the panel leg will affect panel module.

CLIP FASTENER REQUIREMENTS

Two fasteners per clip

Purlins - Fastener #1B - Up to 4" Insulation
 Fastener #142 - Over 4" Insulation

Bar Joists - Fastener #6A

INSTALLATION SEQUENCE

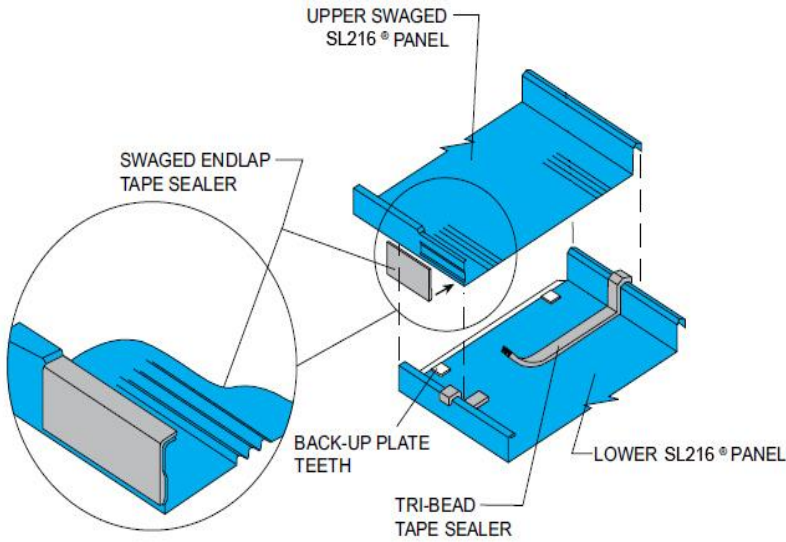

PANEL INSTALLATION SEQUENCE

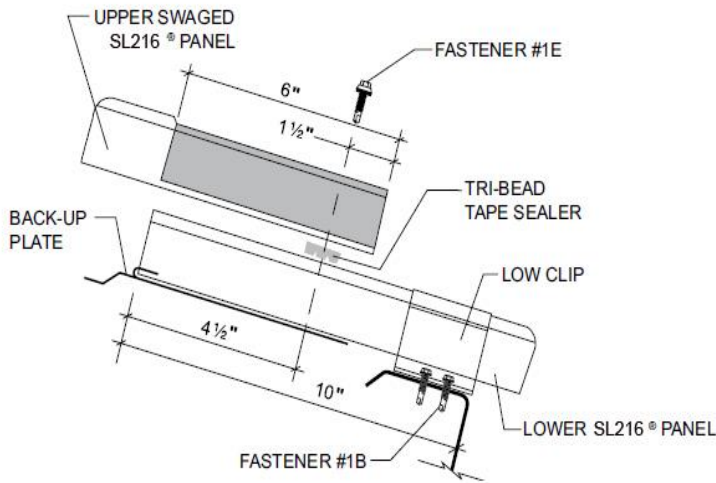

Error! Reference source not found.

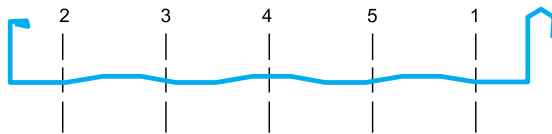

FASTENER SEQUENCE

STEP 6

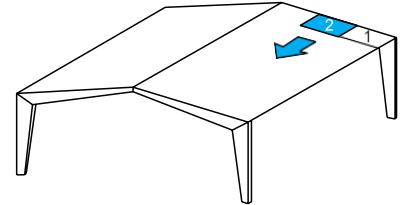

ENDLAP-PANEL

NOTE:

Step 6 applies only where more than one panel is used in a single slope.

Slide a back-up plate onto the upslope end of the bottom panel. Make sure the teeth on top of the back-up plate are on top of the panel. Visually check to ensure that the back-up plate is aligned with the prepunched holes in the panel. At upslope end of bottom panel, install Tri-Bead tape sealer across entire width of panel. At upslope end of bottom panel, Tape sealer must be centered in panel. Apply swaged endlap tape sealer to swaged vertical male leg of upper panel. Pigtail portion of tape sealer must lap over vertical leg of panel.

install upper panel by nesting it over the lower panel for 6". Rotate the male leg of the upper panel under the male leg of the bottom panel, then force the female leg of the upper panel down onto the female leg of the bottom panel. Install Fastener #1E as shown in the proper sequence. Install clips as outlined in Step 5.

Repeat this endlap procedure as required until ridge is reached.

NOTE:

If you are using 12" **SL216®** panels. Use Triple Bead Tape Sealant at endlaps.

INSTALLATION SEQUENCE

STEP 7

RIDGE

At the ridge, the panel should extend 7" past the web of the peak purlin.

At the ridge install a back-up plate as outlined in Step 6.

Install clips as outlined in Step 5.

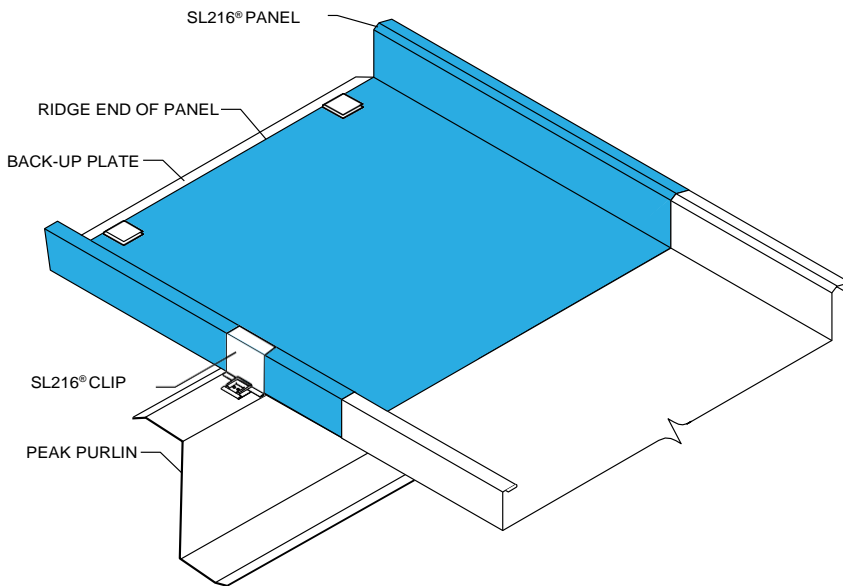
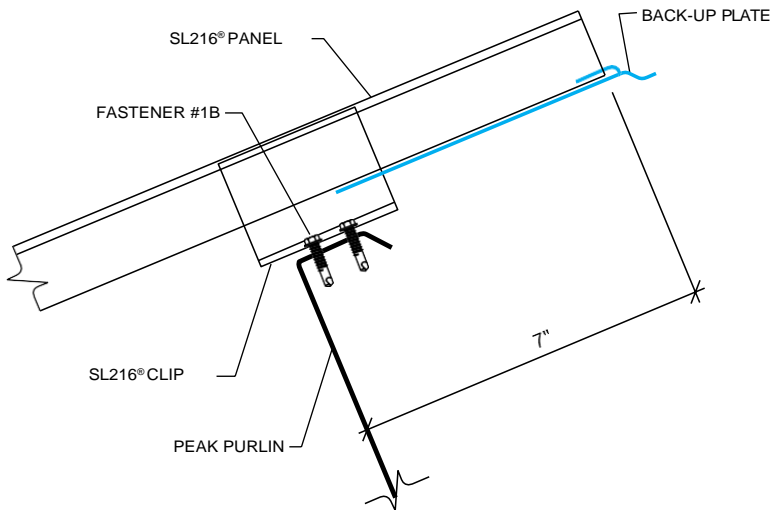

PANEL END SEALANT DETAIL AT RIDGE

INSTALLATION SEQUENCE

STEP 8

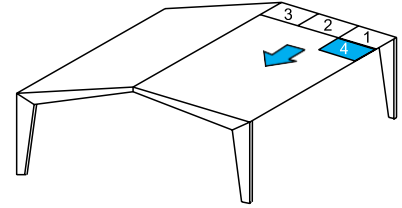

SUBSEQUENT RUNS EAVE

Apply urethane sealant to the male leg of the first panel directly over the Tri-Bead tape sealer at the eave. This will prevent water infiltration through the end of the panel seam.

Position the next panel with the female leg over the male leg of the previous panel with panel ends flush.

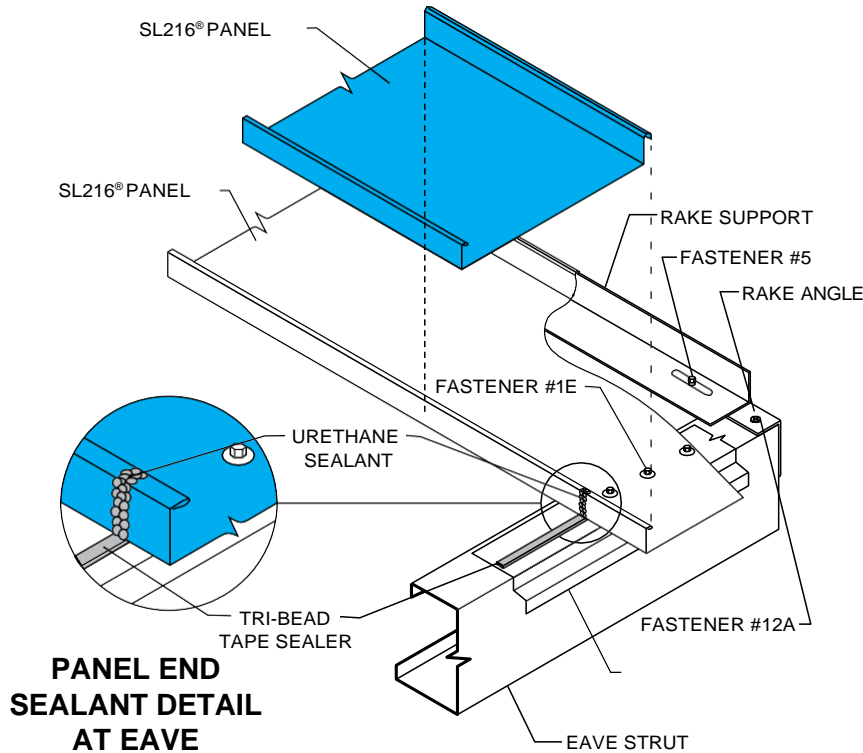

**PANEL END
SEALANT DETAIL
AT EAVE**

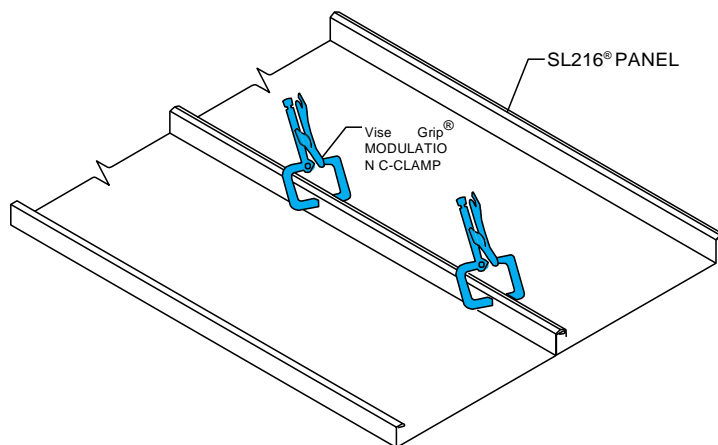

Clamp the panel seam together at both ends. Long panels may require one or more clamps in the middle. This will help hold panel module.

Install fasteners at eave as outlined in Step 4.

Install clips as outlined in Step 5.

Crimp panel seam at all clip locations with hand crimping tool. Panels should be fully seamed with electric seamer as quickly as possible after a section of the roof is completed.

CAUTION
Panel must be crimped at all clip locations as they are installed to provide temporary wind resistance.

INSTALLATION SEQUENCE

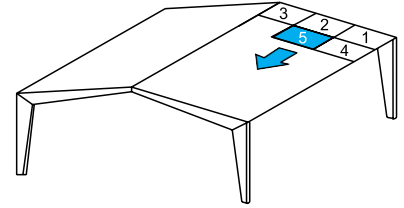

STEP 9

SUBSEQUENT RUNS ENDLAP

Install endlap panels as outlined in Step 6.

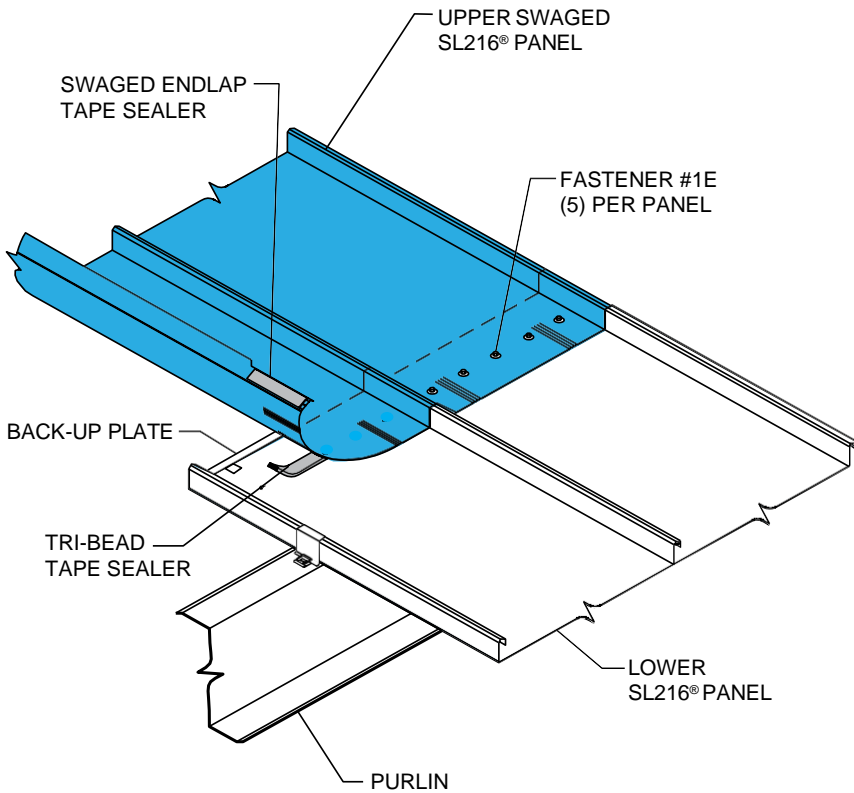

Install clips as described in Step 5.

Repeat endlap procedures as required until ridge is reached.

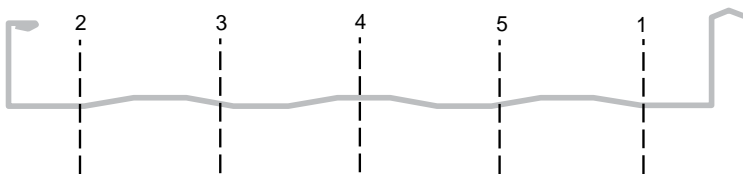
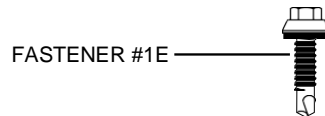

FASTENER SEQUENCE

INSTALLATION SEQUENCE

**STEP
10**

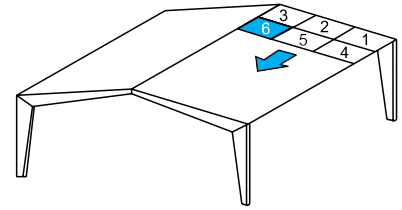

SUBSEQUENT RUNS RIDGE

Install back-up plate and clip as outlined in Step 7.

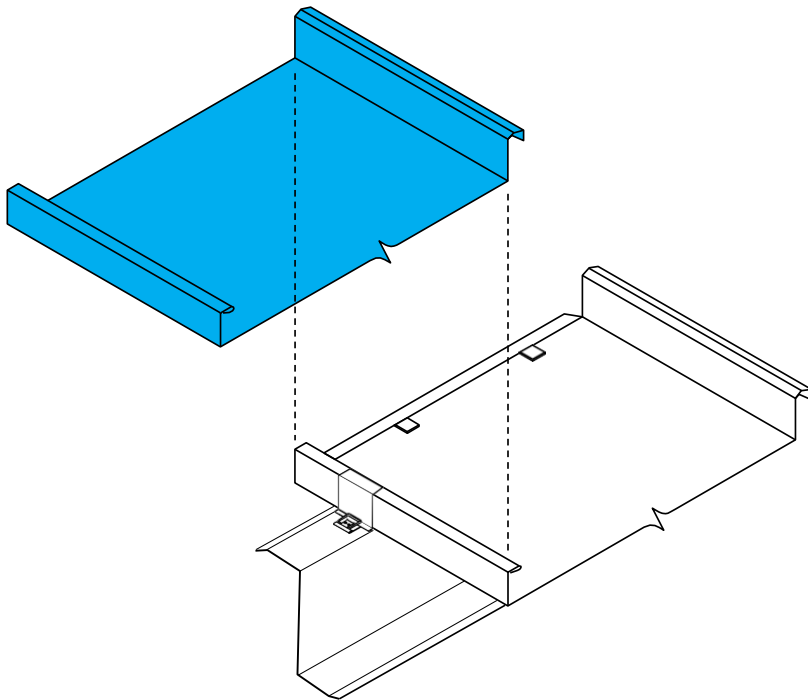

INSTALLATION SEQUENCE

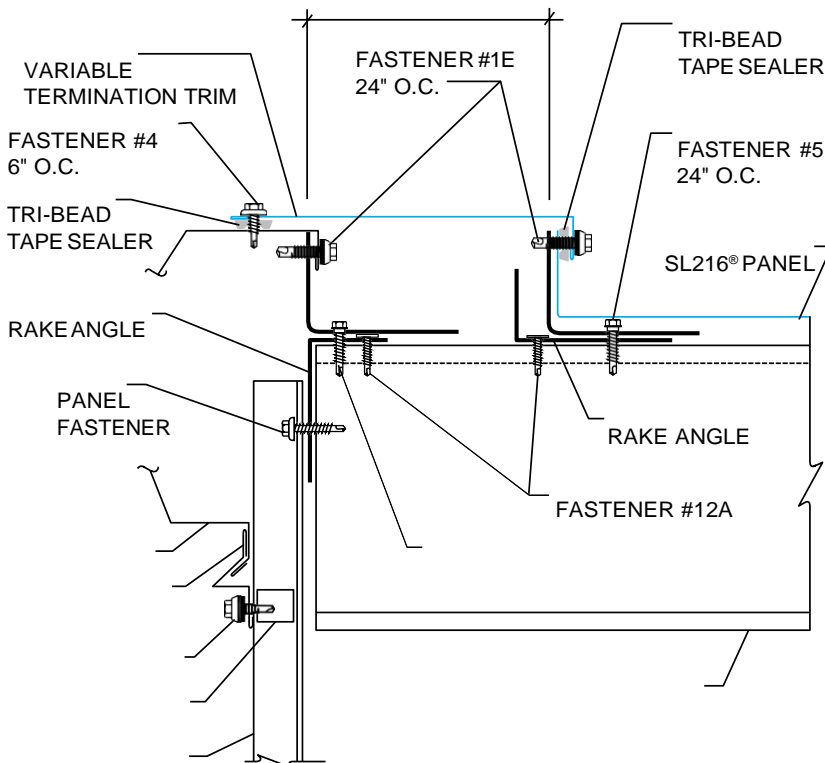
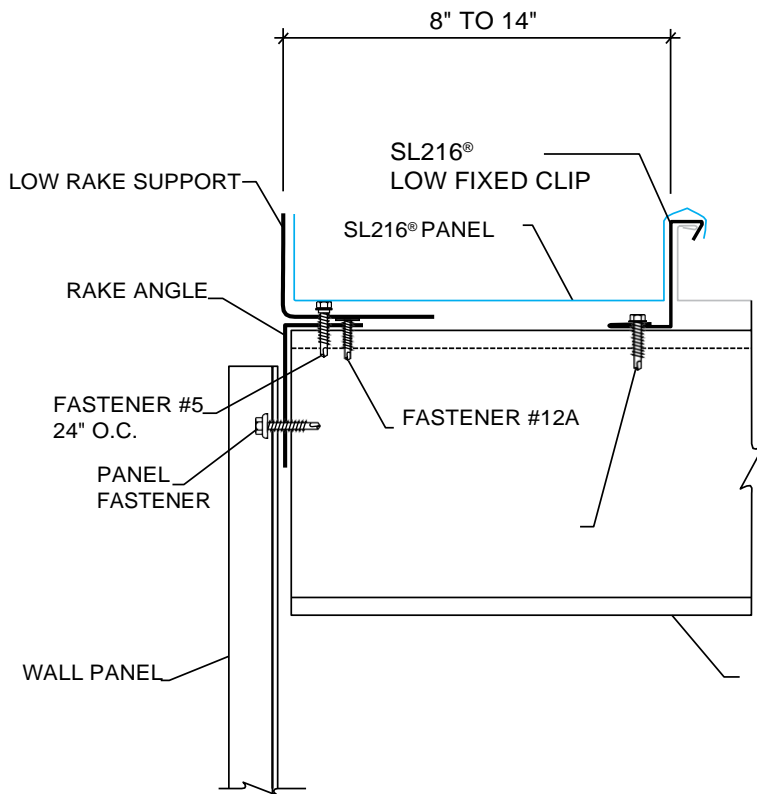

STEP 11

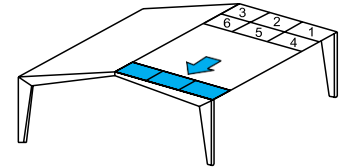

LAST PANEL RUN

Install rake support at the finishing end of the roof as outlined in Step 1.

FINISHING DIMENSION RUN OF 8" TO 14"

Field cut and bend a 2" tall vertical leg on the panels in the last run of roof. The vertical leg must be tight to the rake support angle. Secure the vertical leg to the rake support angle with clamps or temporary fasteners. At the endlap and ridge, a partial back-up plate must be cut.

FINISHING DIMENSION RUN OF LESS THAN 8"

If the width of the last panel run is 8" or less, a second run of rake support angle must be installed for attachment of the vertical leg of the panel. A variable termination trim will be required to seal the gap between the vertical leg of the panel and the rake trim.

The male leg of the panel and the termination trim must be field cut to fit the condition.

INSTALLATION SEQUENCE

**STEP
12**

SEAMING PANEL SIDELAPS

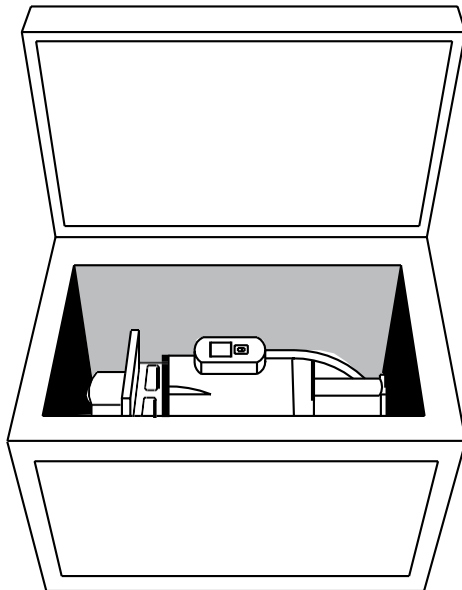

The seamer comes in a specially designed box accompanied by a field manual return shipping label and a hand seaming tool if ordered. **READ THE SEAMER MANUAL THOROUGHLY BEFORE STARTING THE SEAMING OPERATION. FAILURE TO ADHERE TO THESE INSTRUCTIONS MAY RESULT IN PERSONAL INJURY AND DAMAGE TO THE SEAMER AND/OR PANELS. THE ERECTOR WILL BE HELD LIABLE FOR ANY COSTS INCURRED FOR REPLACEMENT OR REPAIR.**

PRE-SEAMING INFORMATION

1. Locate seamer box. Assemble hand seaming tool.
2. Locate power source and check against power requirements in field manual.
3. Check seams for proper engagement.
4. Clean dirt, debris and excess sealant from seams and panel surfaces to avoid interfering with the seaming operation.
5. Panels do not have to be seamed as they are installed. However, to prevent panel separation by a strong wind, panels should be seamed as soon as possible. **ALL PANELS SHOULD BE SEAMED AT THE END OF EACH DAY.**

SEAMING OPERATION

To determine the direction of the seaming process, stand at the eave and look upslope. If the roof is being installed from left to right, the seamer will run from ridge to eave. If the roof is being installed from right to left, the seamer will run from eave to ridge.

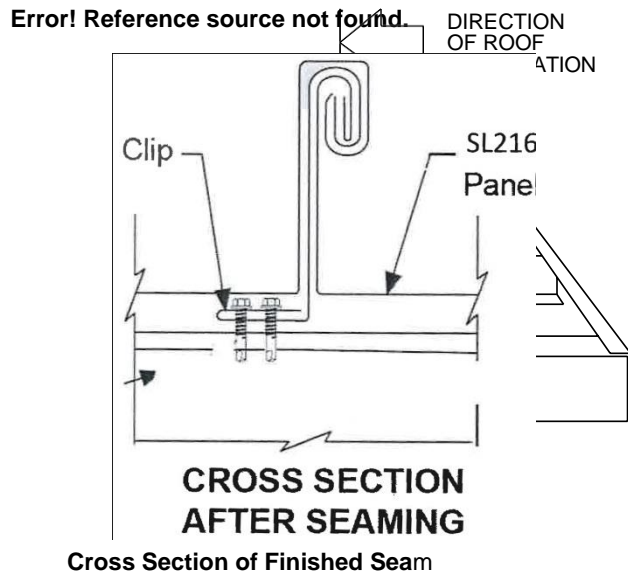

INSPECTION OF SEAM

A visual inspection of the seam should be made to determine if the seam is forming properly. Check seam against the cross section provided. **IF THE SEAMER IS NOT PRODUCING A FINISHED SEAM IDENTICAL TO THE CROSS SECTION PICTURED, STOP AT ONCE AND CALL MANUFACTURER.**

INSTALLATION SEQUENCE

**STEP
12
CONT.**

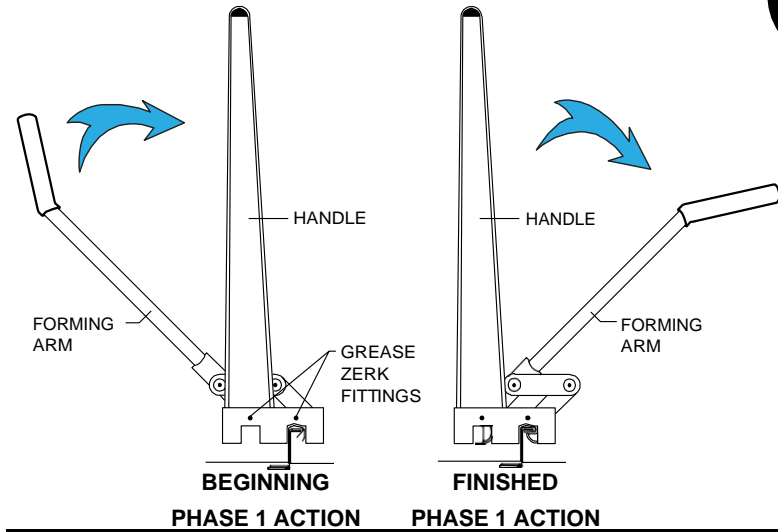

SEAMING OPERATION (Continued)

CAUTION
It is critical that the panel seams are crimped and folded as shown before using the electric seamer. Failure to follow these guidelines will result in damaged seams.

To begin seaming with hand tool, set the hand tool on the seam making sure seam is in the **PHASE 1 Action** slot. Align the edge of the hand tool with the end of the panel. Rotate the forming arm under the handle to produce **PHASE 1** seam. This should be for a total of 16".

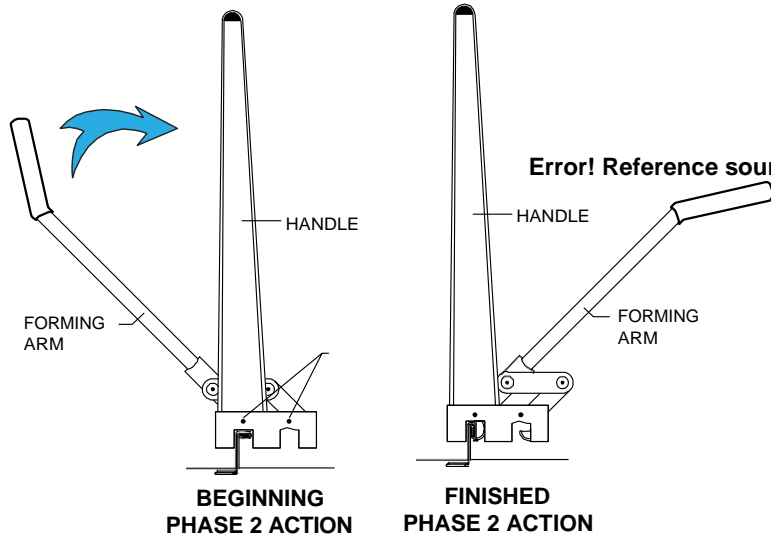

Error! Reference source not found.

Return to the end of the panel to begin **PHASE 2 Action**. Set hand tool onto seam making sure seam is in the **PHASE 2 Action** slot. Align the edge of the hand tool with the edge of the panel. Rotate the forming arm under the handle to produce 4" of finished **PHASE 2** seam. This should be done once per rib. **The relationship of this 4" of finished seam to the 16" of crimped seam is critical to the proper alignment of the rolls in the electric seamer.**

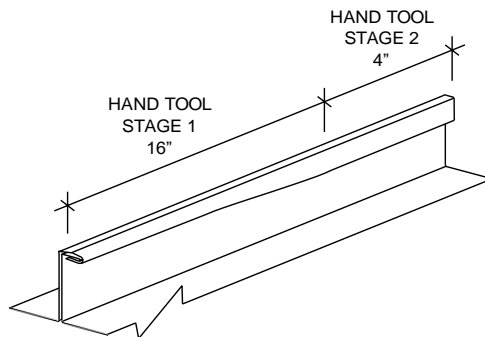

The seam is now ready to accept the electric seamer.

INSTALLATION SEQUENCE

INSTALLATION

INSTALLATION

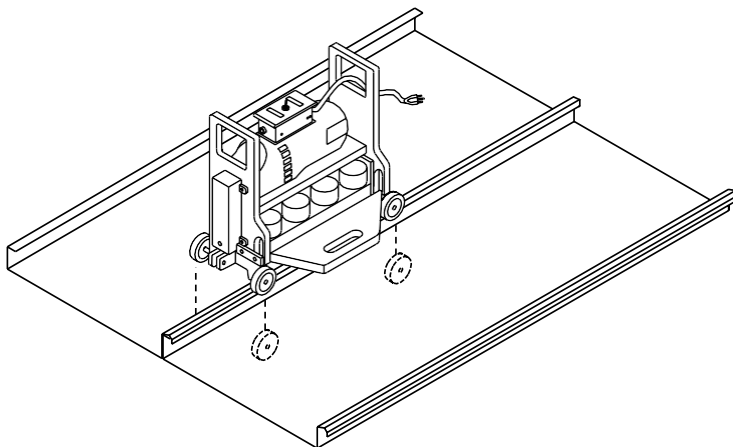
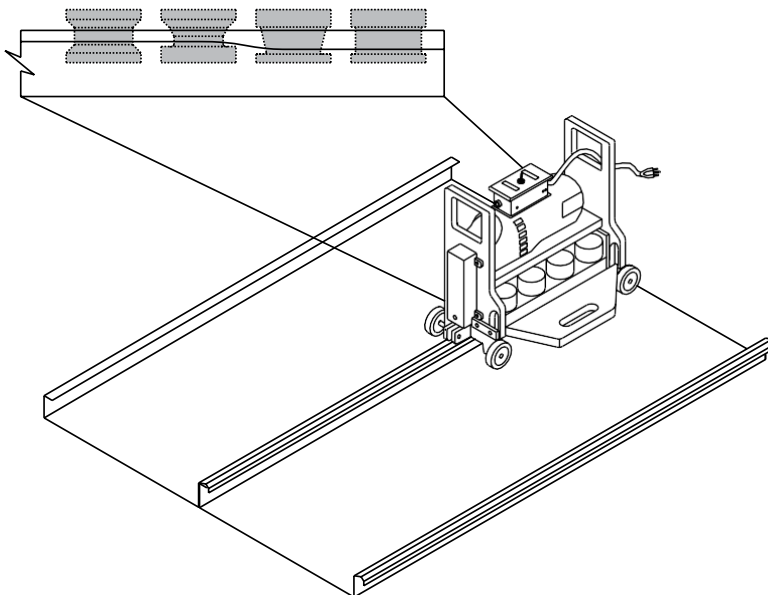
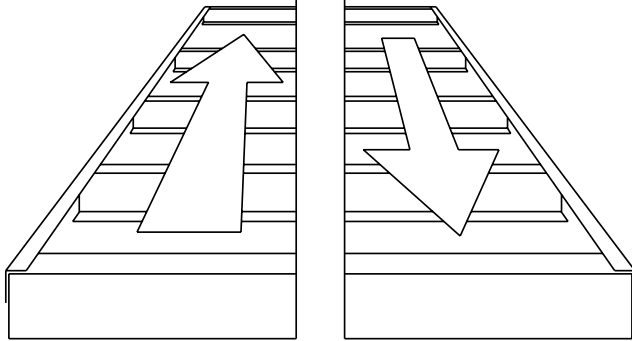

Error! Reference source not found.

SEAMING OPERATION (Continued)

The electric seamer will run in one direction only. To determine the direction of the seamer, stand at the eave and look upslope. If the roof is being installed left to right, the seamer will run upslope. If the roof is being installed right to left, the seamer will run downslope. An arrow is on the seamer to assist you in placing the seamer onto the seam properly. **When the roof has endlaps, the panels will always be installed right to left. When the roof slope is 6 on 12 or greater, panels must run right to left.**

To begin seaming, set seamer on seam with the handles engaged and to the open side of the seam. The rear wheels should be even with the edge of the roof panel. Engage the handles on the panel, and turn the seamer on.

Stop seamer about one foot from end of panels. Disengage handles and remove the electric seamer. Finish seam with hand tool.

CAUTION

- Seamer operation should be closely supervised at all times.
- A safety line should be attached to the seamer.
- Do not entangle the electrical cords in the seamer tooling while it is in operation. This could cause serious injury or death to the operator and severely damage the seamer.
- Electrical cords should be 10-gauge to provide power to the seamer and never be over 200 feet from the electrical source.

INSTALLATION SEQUENCE

Error! Reference source not found. Error!
Reference source not found.

OUTSIDE CLOSURE INSTALLATION

Panels must be seamed before closures can be installed. Install Tri-Bead tape sealer across full width of panels, including under panel seams at ridge. Center of tape sealer should be 1 1/2" from end of panels.

Field cut the end of the outside closure that fits to the open side of the panel seam. Notch and bend the vertical leg of the closure above the end tab back to the dimple formed into the closure. It is important that the closures fit tight to the panel seams to prevent the need for excess urethane sealant at this location.

Install outside closures by rotating the end cut for the panel seam into place first. Then rotate the other end of the outside closure into place. The vertical leg of the outside closure should be 2" from the upslope end of the panel. Attach the outside closure to the panel with Fastener #1 at each prepunched hole in the closure. Before installing the next outside closure, install a piece of Tri-Bead tape sealer onto the top flange of the outside closure previously installed. This is to prevent water being blown between the outside closures where the top flanges overlap. After all closures are in place, install Tri-Bead tape sealer across the top flange.

Use urethane sealant to fill any voids around the panel seams on the upslope side of the outside closures.

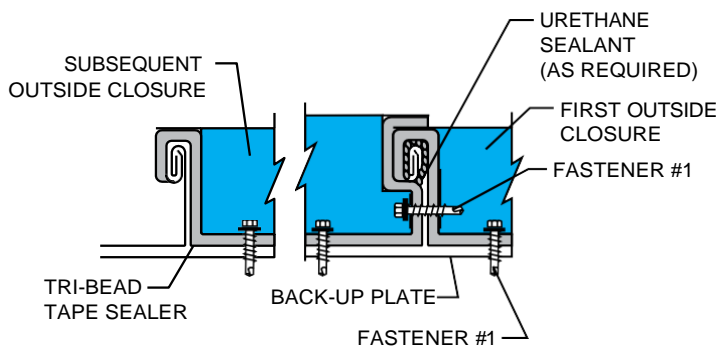
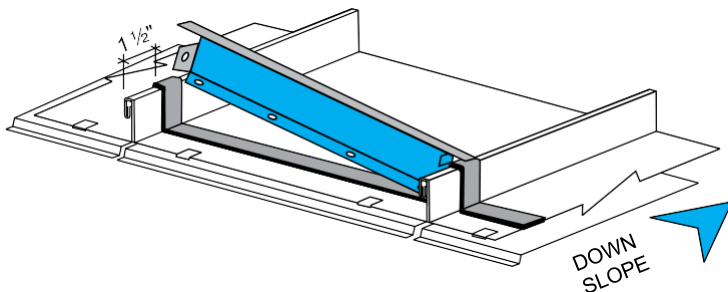
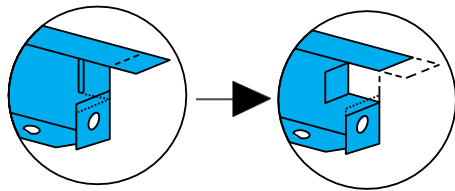
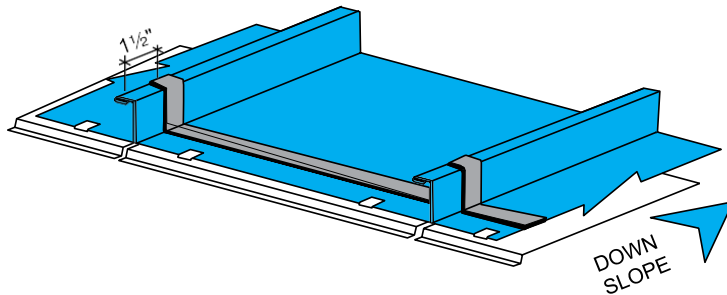

SPECIAL ERECTION TECHNIQUES

UL 90 LIGHT TRANSMITTING PANEL INSTALLATION

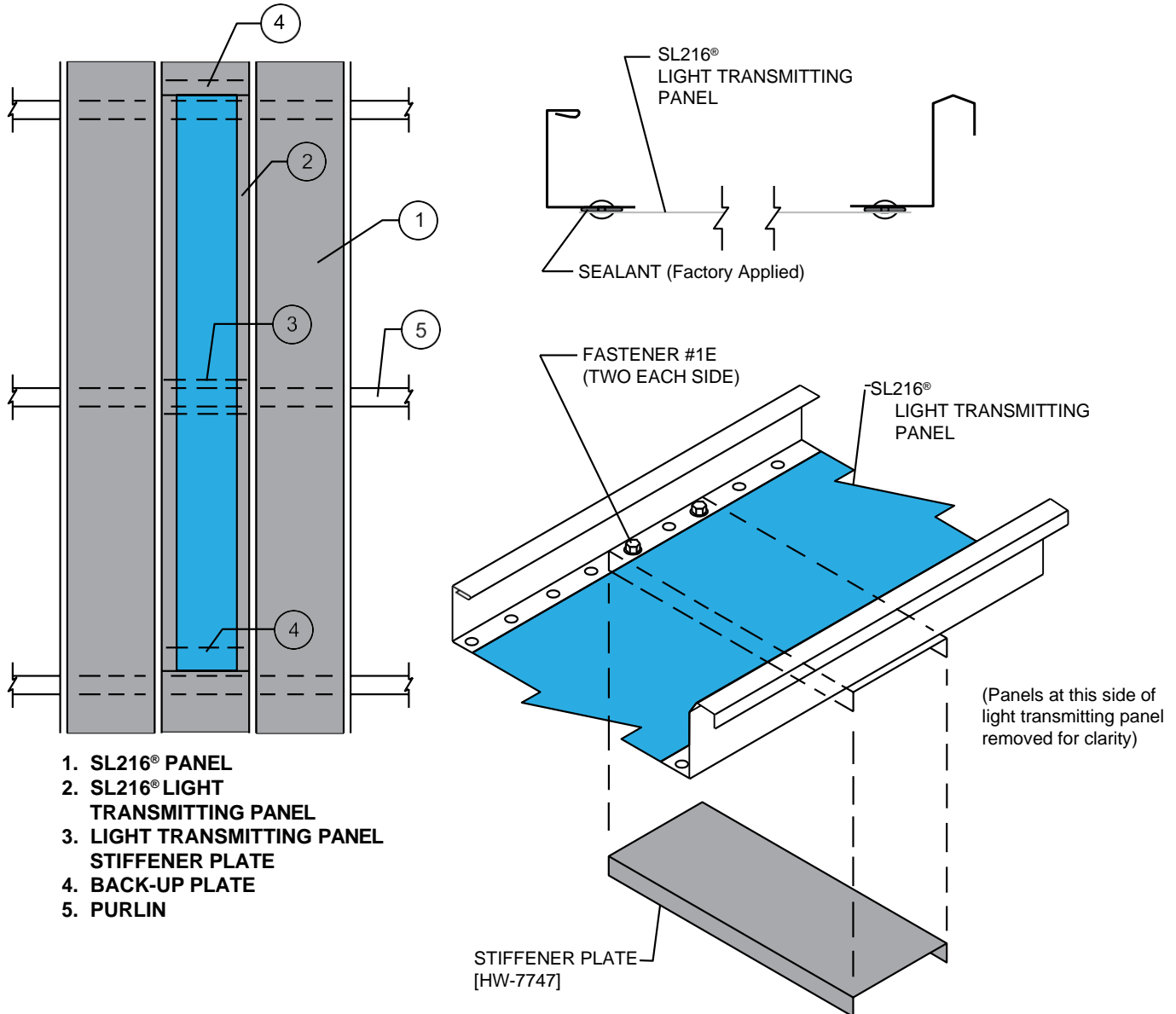

NOTES:

1. Maximum width of purlin flange to be 3 1/2".
2. Stiffener plate is to be field installed on bottom side of light transmitting panel over mid-purlin.
3. Light transmitting panel rivets that obstruct stiffener plate must be drilled out and replaced with Fastener #1E. Minimum two fasteners per side.
4. Stiffener plate must be centered exactly over mid-purlin so that thermal movement of the system is not restrained by the purlin.
5. Endlaps created by the use of light transmitting panels require roof erection to proceed from right to left as viewed from the eave looking toward the ridge.

SPECIAL ERECTION TECHNIQUES

RIVETED RAIL LTP INSTALLATION

STEP 1

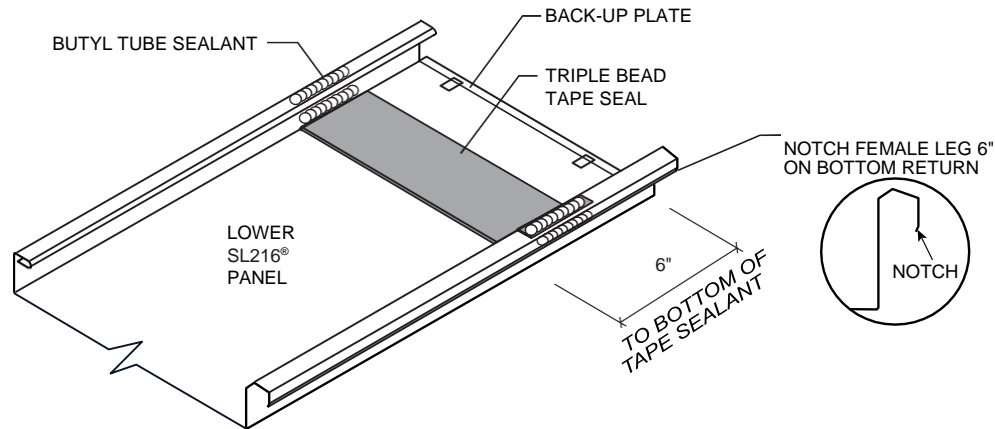

LOWER SL216® PANEL

1. Install Back-up plate on lower panel.
2. Install Triple Bead Tape as shown on lower panel.
3. Install Butyl Sealant as shown up the vertical legs and over the male and female seam.

STEP 2

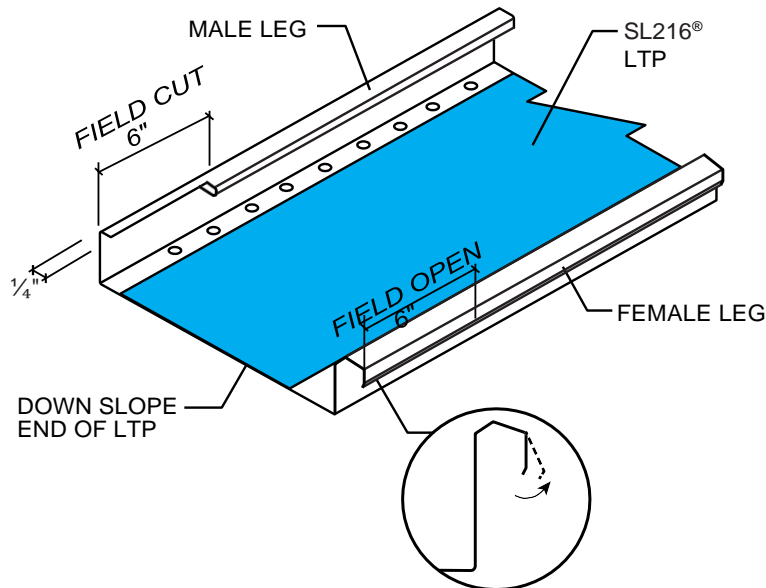

DOWN SLOPE END OF LTP

1. Field cut male leg 6" as shown.
2. Field open female leg 6" to allow panel lap to engage.

SPECIAL ERECTION TECHNIQUES

RIVETED RAIL LTP INSTALLATION (cont'd.)

STEP 3

Error! Reference source not found.

UPPER AND LOWER PANELS

1. C-clamp both vertical male legs together prior to rotating upper panel into place.
2. Lift LTP up slightly in center of panel to help get male and female legs to nest properly.

STEP 4

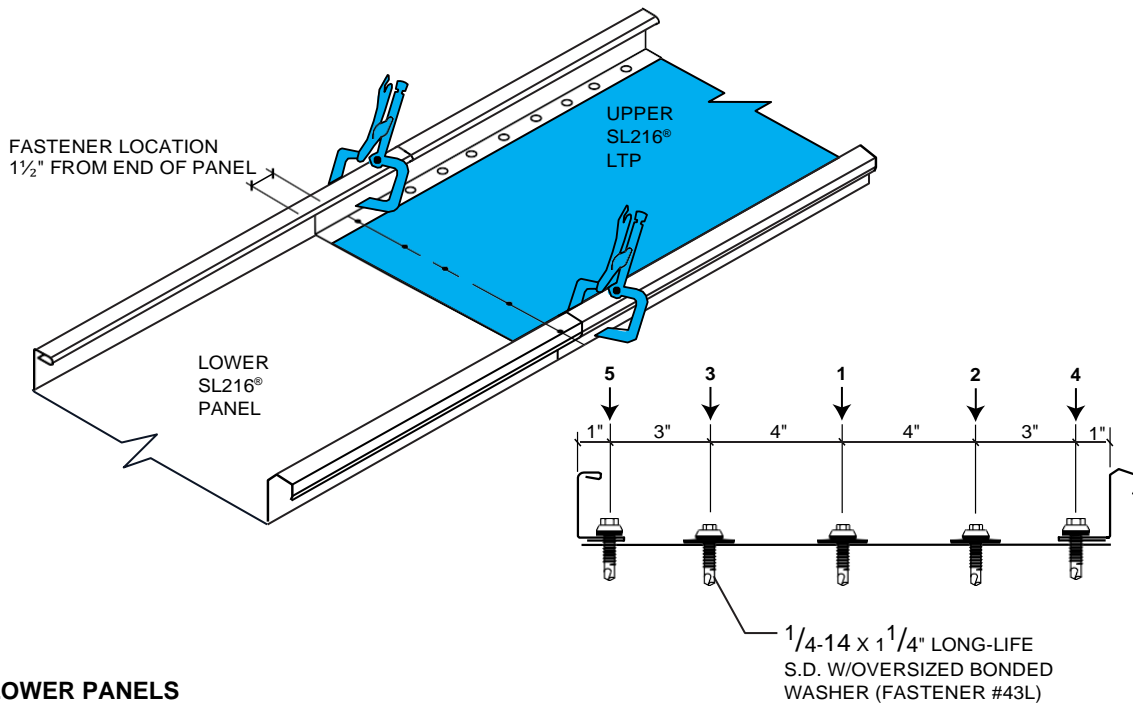

UPPER AND LOWER PANELS

1. C-clamp both female vertical legs together.
2. Install 1/4-14 x 1 1/4" long life fasteners (43L) in the sequence shown.

SPECIAL ERECTION TECHNIQUES

RIVETED RAIL LTP INSTALLATION (cont'd.)

STEP 5

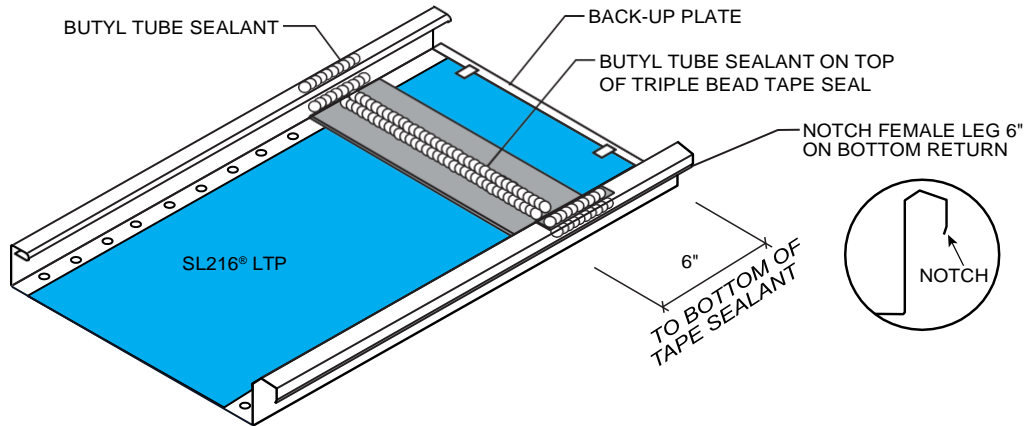

UPSLOPE END OF LTP

1. Install Back-up plate on lower LTP panel.
2. Install Triple Bead Tape as shown on LTP Panel.
3. Install Butyl Sealant as shown up the vertical legs and over the male and female seam.
4. Apply generous bead of butyl sealant on top of triple bead tape sealer.

STEP 6

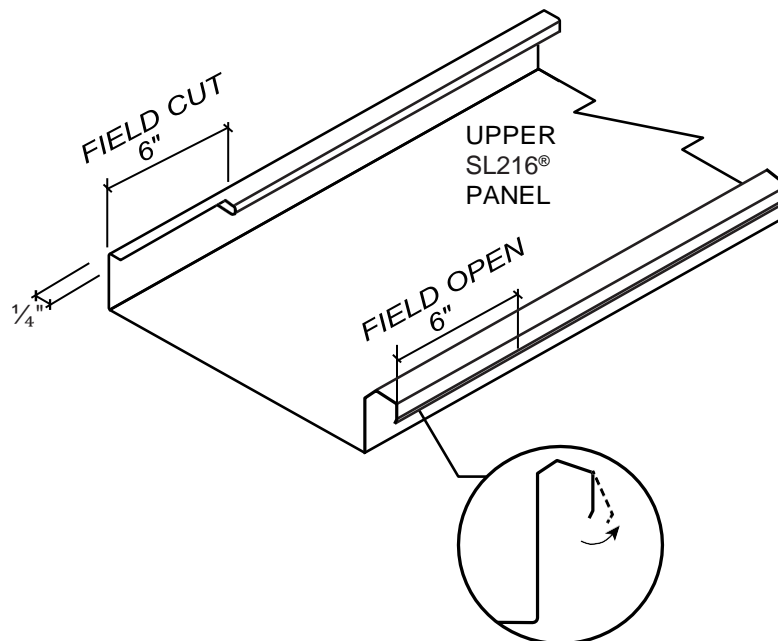

UPPER SL216 PANEL DOWN SLOPE END

1. Field cut male leg 6" as shown.
2. Field open female leg 6" to allow panel lap to engage..

SPECIAL ERECTION TECHNIQUES

RIVETED RAIL LTP INSTALLATION (cont'd.)

STEP 7

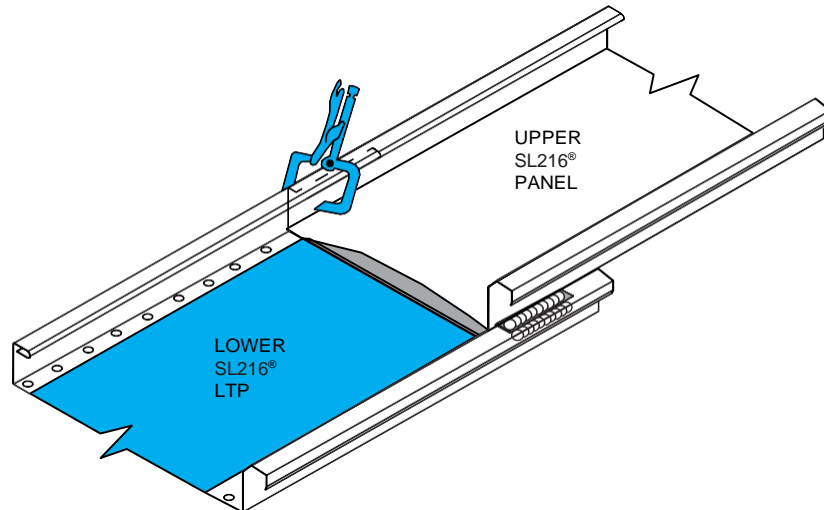

UPPER AND LOWER PANELS

1. C-clamp both vertical male legs together prior to rotating upper panel into place.
2. Lift panel up slightly in center of panel to help get male and female legs to nest properly.

STEP 8

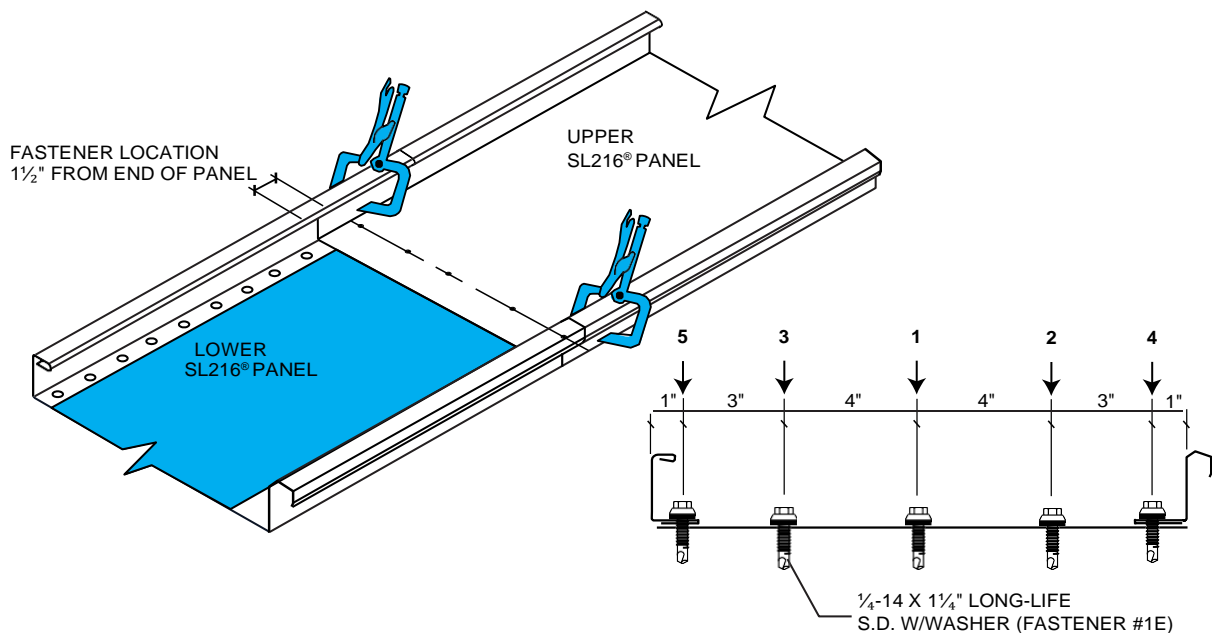

UPPER AND LOWER PANELS

1. C-clamp both female vertical legs together.
2. Install 1/4-14 x 1 1/4" long life fasteners (#1E) in the sequence as shown.

SPECIAL ERECTION TECHNIQUES

ROOF CURB INSTALLATION INSTRUCTIONS

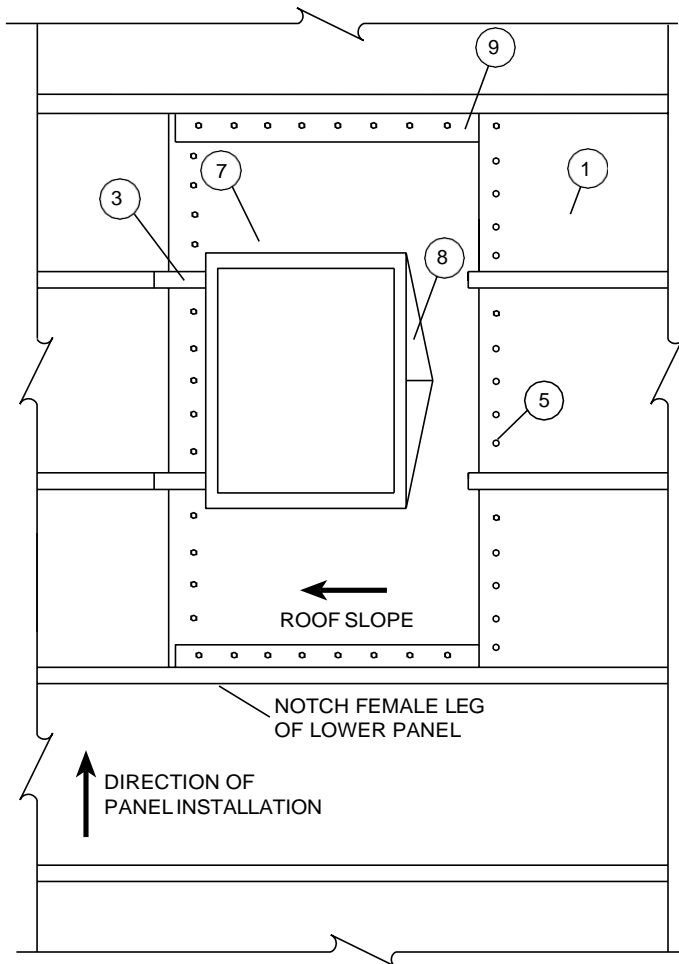
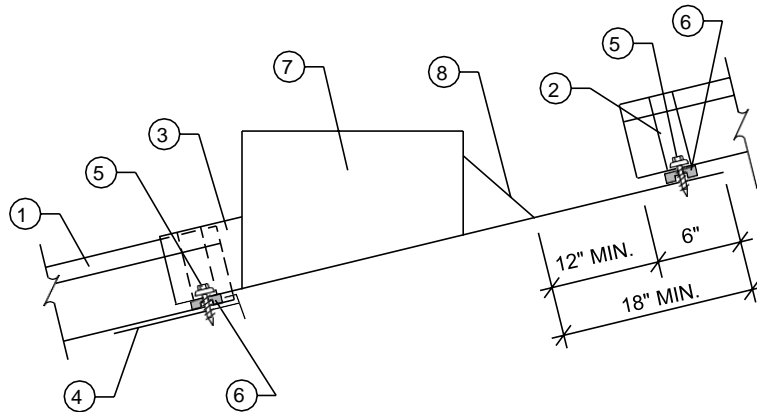

1. SL216® Panel
2. Urethane Sealant
3. Outside Cap Cell
4. Back-up Plate
5. Fastener #1E
6. Tri-bead Tape Sealer
7. Roof Curb Made From Structural Aluminum (Min. .080 Thickness)
8. Water Diverter
9. Panel Fins (to be cut from an extra panel the length equal to length of the curb).

When ordering curbs, specify one-piece curbs as shown on this page.

VULCAN recommends that only one-piece .080 Aluminum (Min.) roof curbs be used with the SL216® roof system. The roof curb will be installed under the roof panels on the upslope end and over the panels at the downslope end. To accomplish this, the roof panels must be endlapped at the upslope and downslope end of the curb. This allows both ends of the curb to shed water and places the heavier gauge metal of the curb under the roof panels for better resistance to foot traffic. The exception is at the downslope end where the curb is on top of the roof panels. Since there are endlaps at this area, back-up plates provide support.

Outside cap cells (for bottom) are used to seal the panel to the roof curb. If the curb must be located in a precise location, order the cap cells loose for field installation.

For the purpose of these instructions, a curb with a factory attached cap cell is illustrated. Panels are assumed to be blank and installed right to left.

CAUTION

It is the user's responsibility to ensure that openings cut into the roof for installation of roof curbs comply with State, Federal and OSHA regulations and laws, including, but not limited to, guarding roof openings with plywood, fixed standard railings, or other acceptable safety controls that prevent fall-through.

SPECIAL ERECTION TECHNIQUES

CURB INSTALLATION FLOATING ROOF CURB SUPPORT GUIDE

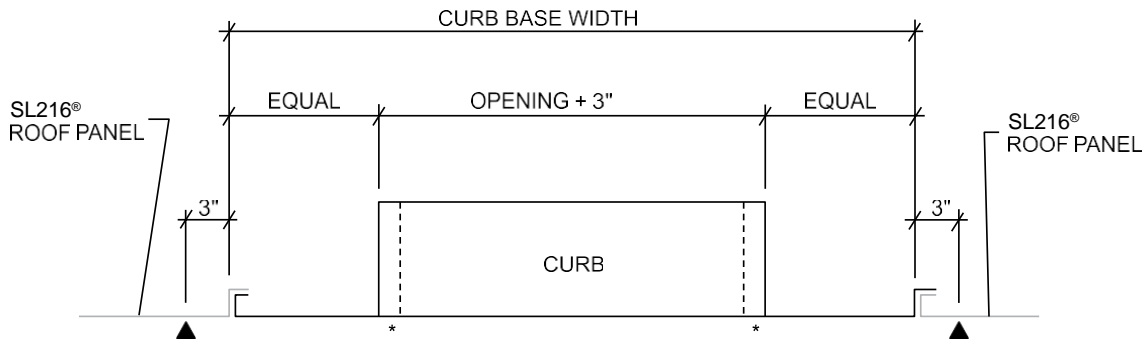
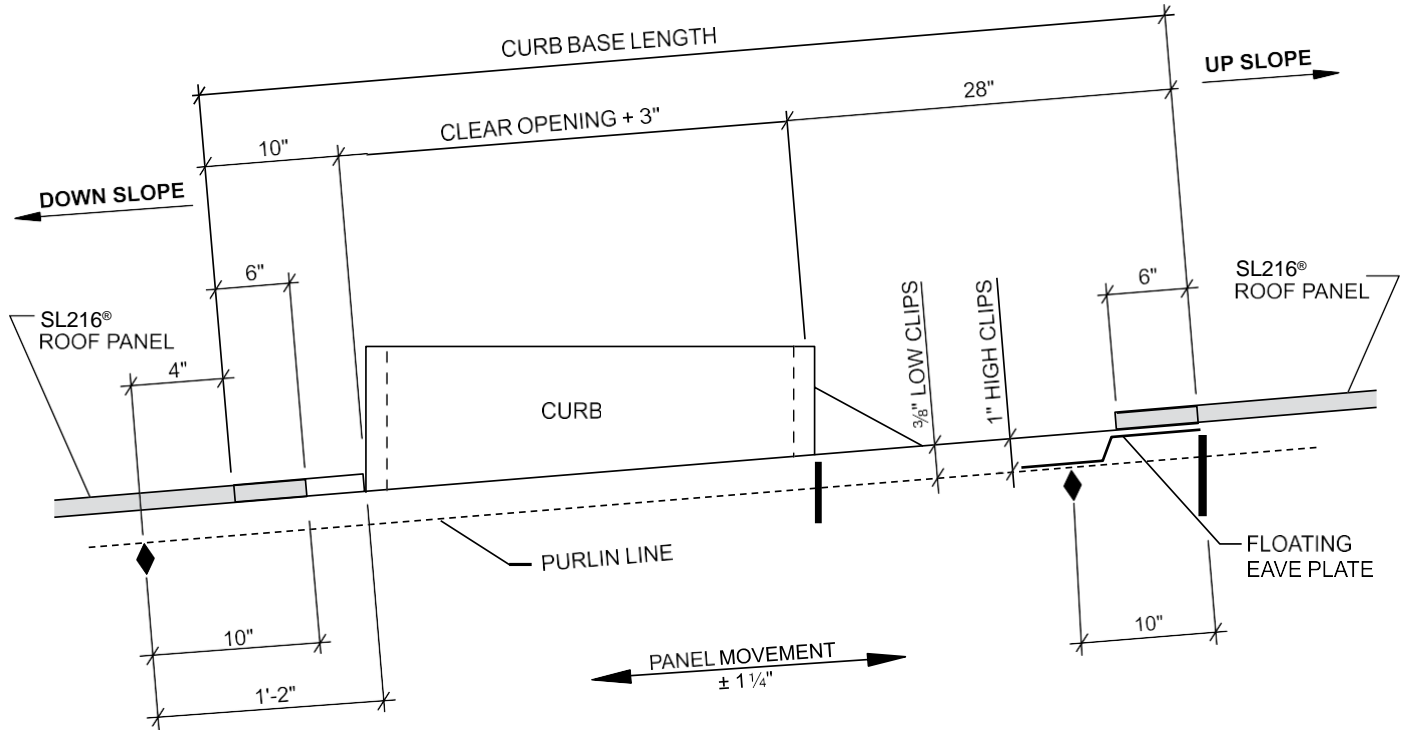

INDICATES ROOF PANEL SUPPORTS

* ADDITIONAL UPLIFT SUPPORTS ARE REQUIRED FOR THE ATTACHMENT OF THE CURB UP LIFT PLATES ONLY.

CAUTION

It is the user's responsibility to ensure that openings cut into the roof for installation of roof curbs comply with State, Federal and OSHA regulations and laws, including, but not limited to, guarding roof openings with plywood, fixed standard railings, or other acceptable safety controls that prevent fall-through.

SPECIAL ERECTION TECHNIQUES

CURB INSTALLATION CURB BASE INSTALLATION #1

Error! Reference source not found.

NOTES:

1. Install all lower roof panels to support the curb base.
2. Install back up plates.

CAUTION

It is the user's responsibility to ensure that openings cut into the roof for installation of roof curbs comply with State, Federal and OSHA regulations and laws, including, but not limited to, guarding roof openings with plywood, fixed standard railings, or other acceptable safety controls that prevent fall-through.

SPECIAL ERECTION TECHNIQUES

CURB INSTALLATION CURB BASE INSTALLATION #2

Error! Reference source not found.



NOTES:

1. Apply Triple Bead tape sealer (HW-502) on roof panels as shown

CAUTION

It is the user's responsibility to ensure that openings cut into the roof for installation of roof curbs comply with State, Federal and OSHA regulations and laws, including, but not limited to, guarding roof openings with plywood, fixed standard railings, or other acceptable safety controls that prevent fall-through.

SPECIAL ERECTION TECHNIQUES

CURB INSTALLATION CURB BASE INSTALLATION #3

Error! Reference source not found.

← SHEETING DIRECTION

NOTES:

1. For field located Panel Fin Caps, notch Curb Base at all panel Fins.
2. Install Curb Base on lower roof panels with a 3" End Lap.

CAUTION

It is the user's responsibility to ensure that openings cut into the roof for installation of roof curbs comply with State, Federal and OSHA regulations and laws, including, but not limited to, guarding roof openings with plywood, fixed standard railings, or other acceptable safety controls that prevent fall-through.

SPECIAL ERECTION TECHNIQUES

CURB INSTALLATION CURB BASE INSTALLATION #4

Error! Reference source not found.



NOTES:

1. Attach the Curb Base to the roof panels.

CAUTION

It is the user's responsibility to ensure that openings cut into the roof for installation of roof curbs comply with State, Federal and OSHA regulations and laws, including, but not limited to, guarding roof openings with plywood, fixed standard railings, or other acceptable safety controls that prevent fall-through.

SPECIAL ERECTION TECHNIQUES

CURB INSTALLATION CAP CELL INSTALLATION

Error! Reference source not found.

← SHEETING DIRECTION

NOTES:

1. Fill Fin cavity of Cap Cell with Urethane Tube Sealant. Apply Triple Bead tape sealer (HW-502) on the bottom of (2) loose the Cap Cell, install over the panel Fins and attach with (6) Fastener #1E.

CAUTION

It is the user's responsibility to ensure that openings cut into the roof for installation of roof curbs comply with State, Federal and OSHA regulations and laws, including, but not limited to, guarding roof openings with plywood, fixed standard railings, or other acceptable safety controls that prevent fall-through.

SUBJECT TO CHANGE WITHOUT NOTICE

SEE www.vulcansteel.com FOR CURRENT INFORMATION

SL-53

STEP 1

STEP 2

SPECIAL ERECTION TECHNIQUES

CURB INSTALLATION CURB PANEL FIN PREPARATION

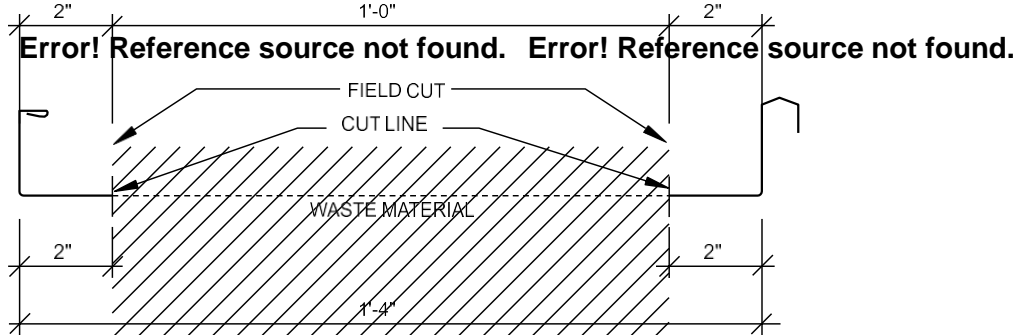

NOTES:

1. Field cut male and female panel ribs from an extra roof panel supplied by the building manufacturer.

CAUTION

It is the user's responsibility to ensure that openings cut into the roof for installation of roof curbs comply with State, Federal and OSHA regulations and laws, including, but not limited to, guarding roof openings with plywood, fixed standard railings, or other acceptable safety controls that prevent fall-through.

WASTE MATERIAL

SPECIAL ERECTION TECHNIQUES

CURB INSTALLATION FEMALE PANEL FIN INSTALLATION

Error! Reference source not found.

NOTES:

1. Install Triple Bead tape sealer (HW-502) to panel #2 Male Fin, and along the edge of the Curb Base.
2. Install the Female Panel Rib over the tape sealer and attach with Fastener # 1E at 12" O.C.

CAUTION

It is the user's responsibility to ensure that openings cut into the roof for installation of roof curbs comply with State, Federal and OSHA regulations and laws, including, but not limited to, guarding roof openings with plywood, fixed standard railings, or other acceptable safety controls that prevent fall-through.

SPECIAL ERECTION TECHNIQUES

CURB INSTALLATION MALE PANEL FIN INSTALLATION

Error! Reference source not found.

NOTES:

1. Notch the male Panel Fin. Apply Triple Bead tape sealer (HW-502) to the top and side of the Male Panel Fin.
2. Apply Triple Bead tape sealer on the Curb Base under the male Panel Fin.
3. Insert the field cut male Panel Fin on top of the Triple Bead tape sealer.

CAUTION

It is the user's responsibility to ensure that openings cut into the roof for installation of roof curbs comply with State, Federal and OSHA regulations and laws, including, but not limited to, guarding roof openings with plywood, fixed standard railings, or other acceptable safety controls that prevent fall-through.

SPECIAL ERECTION TECHNIQUES

CURB INSTALLATION CURB BASE INSTALLATION #5

Error! Reference source not found.



CAUTION

It is the user's responsibility to ensure that openings cut into the roof for installation of roof curbs comply with State, Federal and OSHA regulations and laws, including, but not limited to, guarding roof openings with plywood, fixed standard railings, or other acceptable safety controls that prevent fall-through.

SPECIAL ERECTION TECHNIQUES

CURB INSTALLATION CURB BASE INSTALLATION #6

Error! Reference source not found.



NOTES:

1. Apply Triple Bead tape sealer (HW-502) on Curb Base at the up hill end.

CAUTION

It is the user's responsibility to ensure that openings cut into the roof for installation of roof curbs comply with State, Federal and OSHA regulations and laws, including, but not limited to, guarding roof openings with plywood, fixed standard railings, or other acceptable safety controls that prevent fall-through.

SPECIAL ERECTION TECHNIQUES

CURB INSTALLATION CURB BASE INSTALLATION #7

Error! Reference source not found.

NOTES:

1. Apply Triple Bead tape sealer (HW-502) between the Panel Fins on Panels #5 and #6 for water seal.

CAUTION

It is the user's responsibility to ensure that openings cut into the roof for installation of roof curbs comply with State, Federal and OSHA regulations and laws, including, but not limited to, guarding roof openings with plywood, fixed standard railings, or other acceptable safety controls that prevent fall-through.

SPECIAL ERECTION TECHNIQUES

CURB INSTALLATION CURB BASE INSTALLATION #8

Error! Reference source not found.

NOTES:

1. Install Roof Panels #5, #6, & #7 to the Curb Base on top of the tape sealer with Fastener #1E (5 per panel).
2. Install Roof Panel #8.

CAUTION

It is the user's responsibility to ensure that openings cut into the roof for installation of roof curbs comply with State, Federal and OSHA regulations and laws, including, but not limited to, guarding roof openings with plywood, fixed standard railings, or other acceptable safety controls that prevent fall-through.

SPECIAL ERECTION TECHNIQUES

CURB INSTALLATION UPLIFT PLATE DETAIL

Error! Reference source not found.

Error! Reference source not found.

Error! Reference source not found.

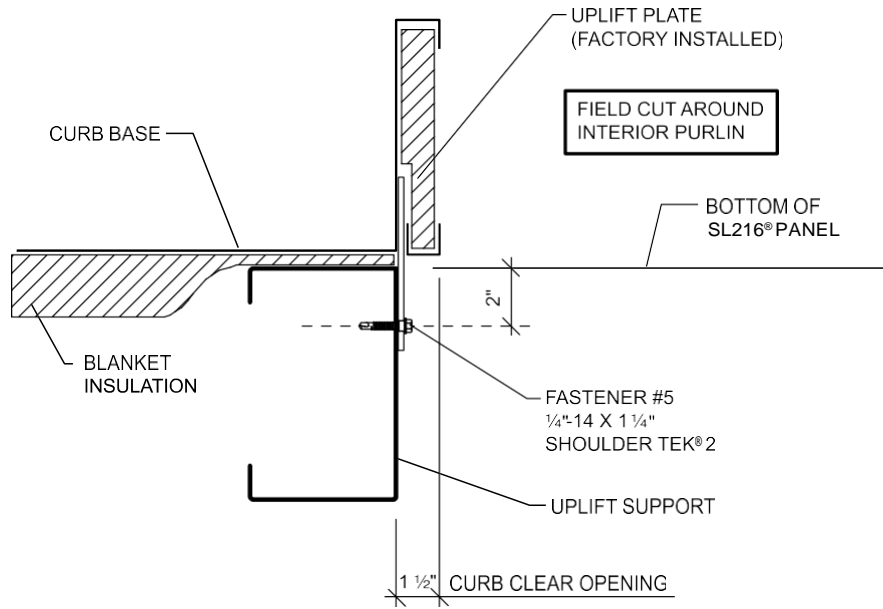

CAUTION

It is the user's responsibility to ensure that openings cut into the roof for installation of roof curbs comply with State, Federal and OSHA regulations and laws, including, but not limited to, guarding roof openings with plywood, fixed standard railings, or other acceptable safety controls that prevent fall-through.

SPECIAL ERECTION TECHNIQUES

CURB INSTALLATION UPLIFT PLATE FIELD NOTCH

Error! Reference source not found.
Error! Reference source not found.

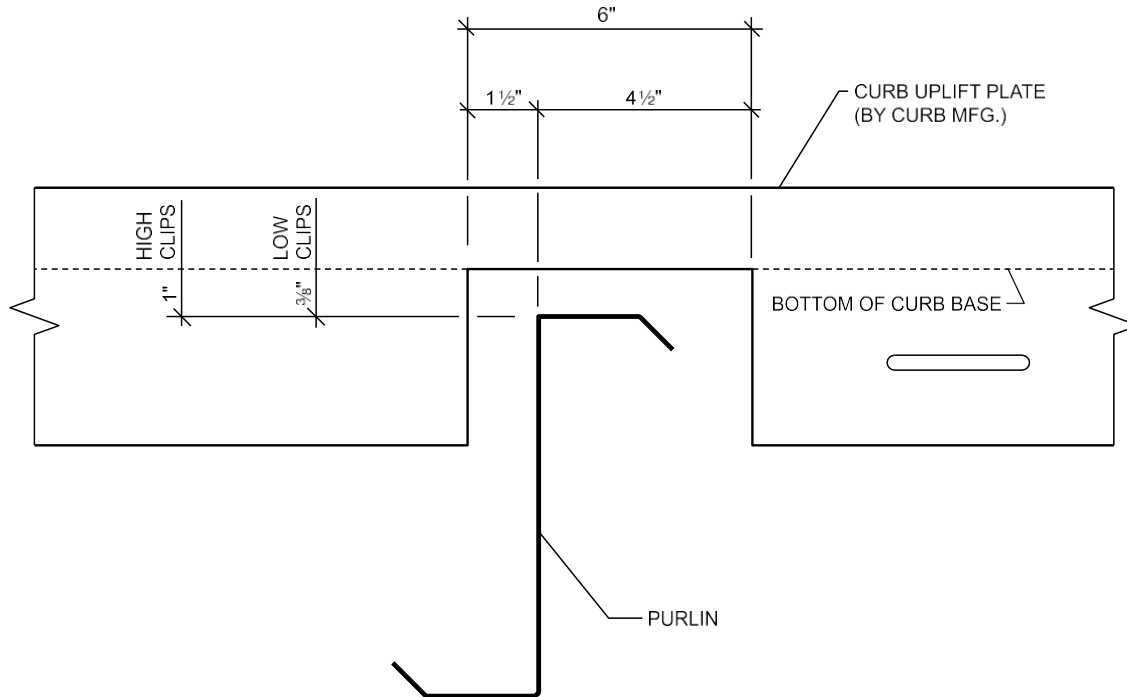

UPLIFT PLATE MUST BE FIELD NOTCHED AROUND THE BUILDING PURLIN TO ALLOW FOR PANEL MOVEMENT.

CAUTION

It is the user's responsibility to ensure that openings cut into the roof for installation of roof curbs comply with State, Federal and OSHA regulations and laws, including, but not limited to, guarding roof openings with plywood, fixed standard railings, or other acceptable safety controls that prevent fall-through.

SPECIAL ERECTION TECHNIQUES

CURB INSTALLATION DOWN SLOPE CURB BASE END LAP

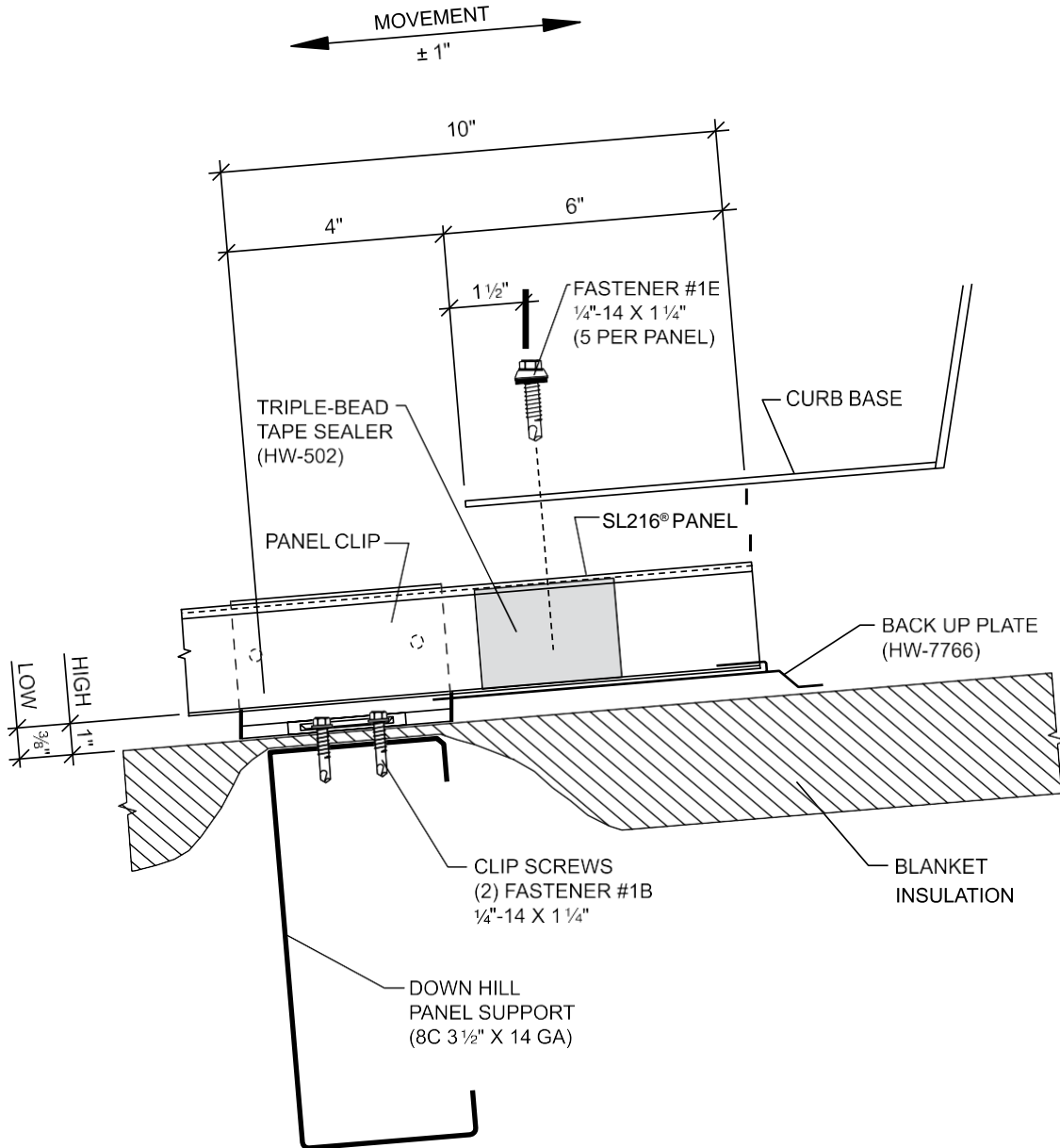

CAUTION

It is the user's responsibility to ensure that openings cut into the roof for installation of roof curbs comply with State, Federal and OSHA regulations and laws, including, but not limited to, guarding roof openings with plywood, fixed standard railings, or other acceptable safety controls that prevent fall-through.

SPECIAL ERECTION TECHNIQUES

CURB INSTALLATION UP SLOPE CURB BASE END LAP

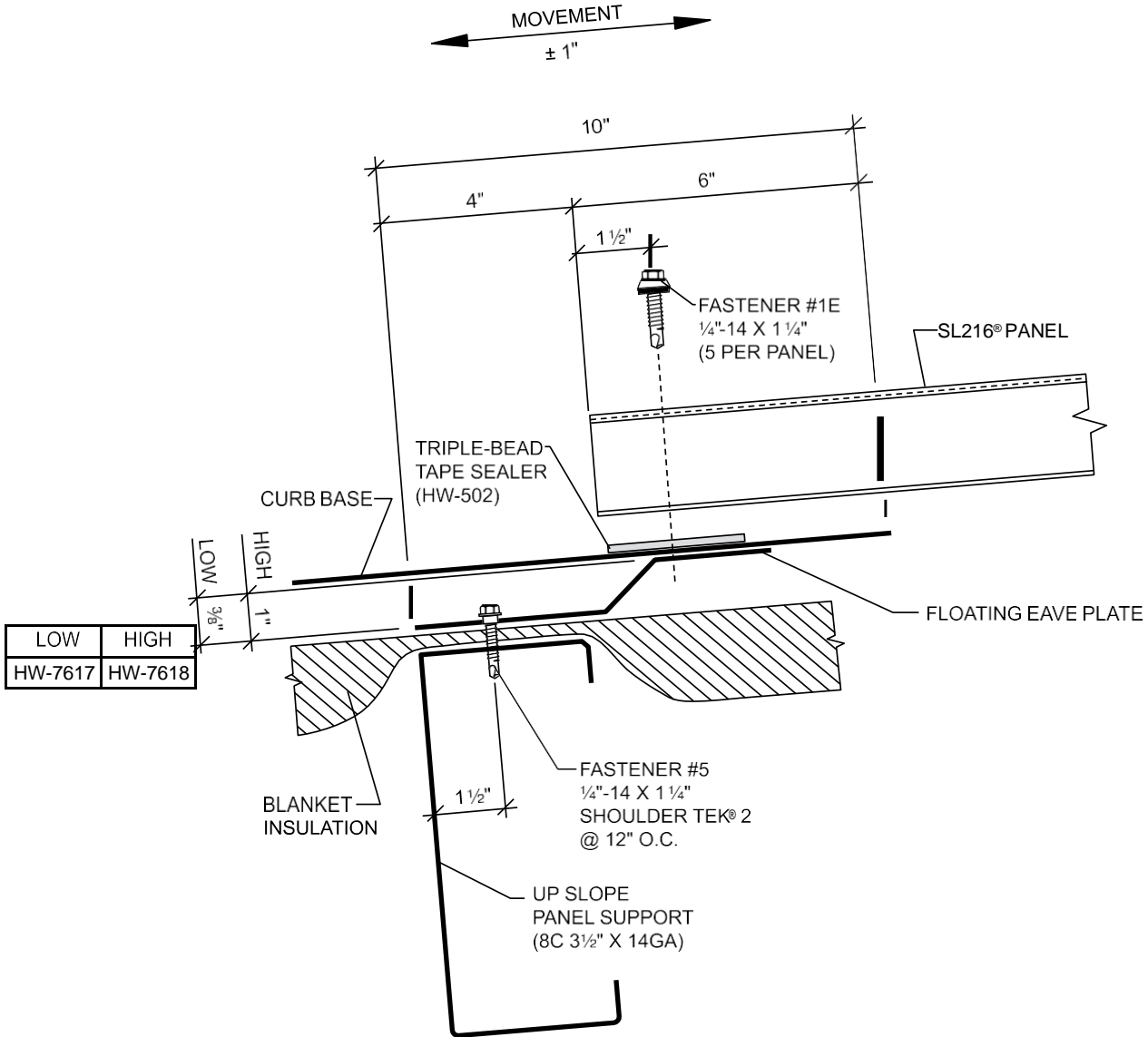

CAUTION

It is the user's responsibility to ensure that openings cut into the roof for installation of roof curbs comply with State, Federal and OSHA regulations and laws, including, but not limited to, guarding roof openings with plywood, fixed standard railings, or other acceptable safety controls that prevent fall-through.

SPECIAL ERECTION TECHNIQUES

PIPE PENETRATION INSTALLATION

RECOMMENDED SMALL AND LARGE PIPE PENETRATION INSTALLATION

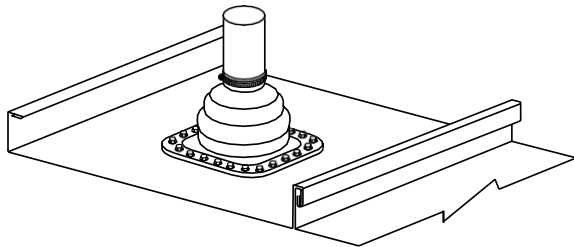

RIGHT WAY

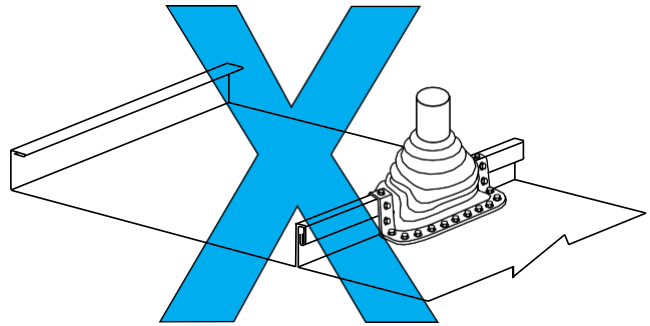

WRONG WAY

RECOMMENDED SMALL PIPE PENETRATION INSTALLATION

INSTALL PIPE IN CENTER OF PANEL TO ALLOW BASE OF RUBBER ROOF JACK TO LAY FLAT ON PANEL.

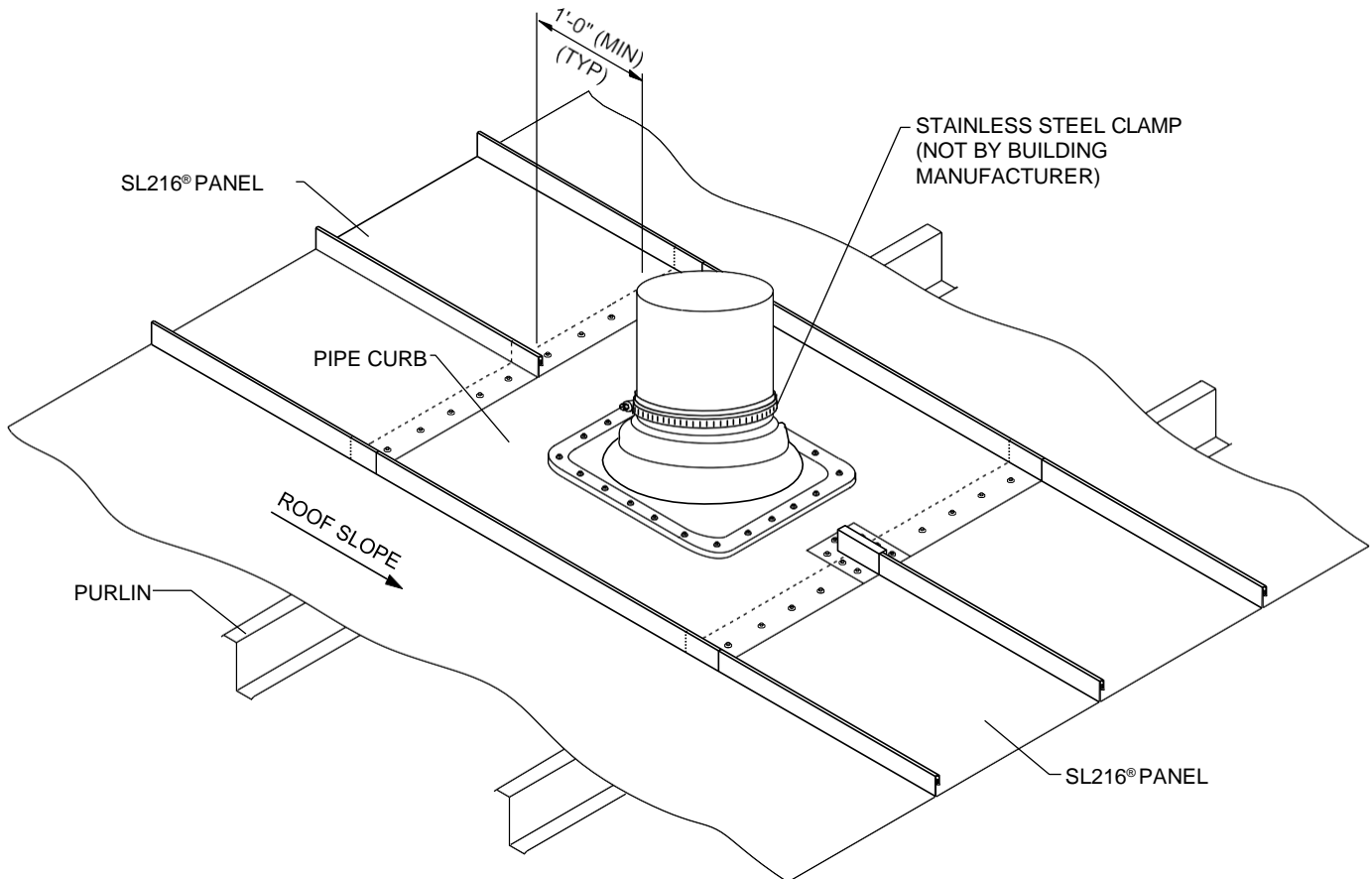

RECOMMENDED LARGE PIPE PENETRATION INSTALLATION

THIS METHOD TO BE USED IN ALL CASES WHERE A PIPE PENETRATION INTERSECTS A PANEL RIB OR WHEN THE PIPE IS TOO LARGE AND WILL NOT ALLOW ADEQUATE WATER FLOW DOWN THE PANEL.

SPECIAL ERECTION TECHNIQUES

PIPE PENETRATION INSTALLATION DECK-TIGHT INSTALLATION

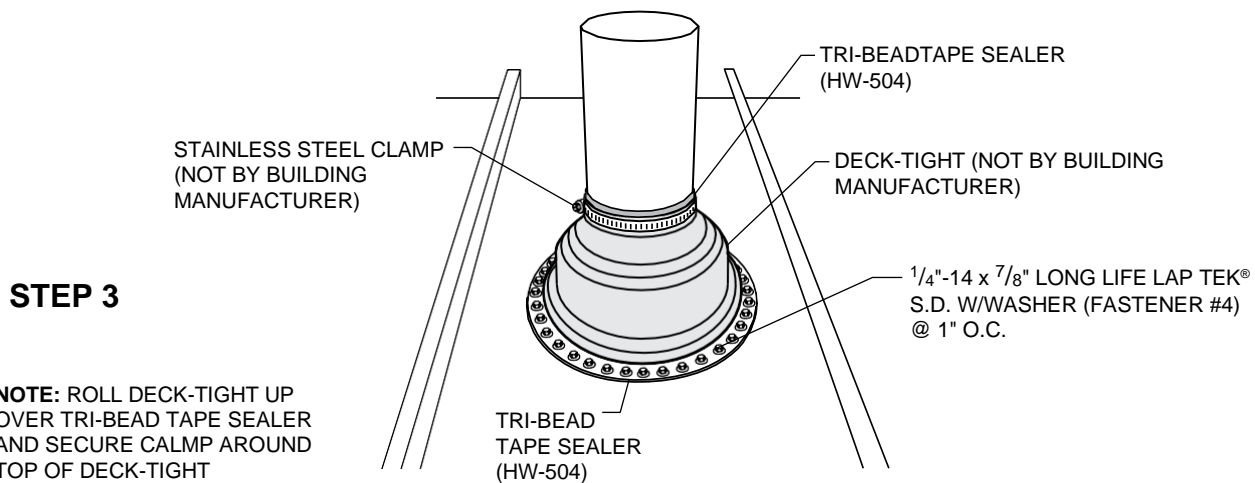
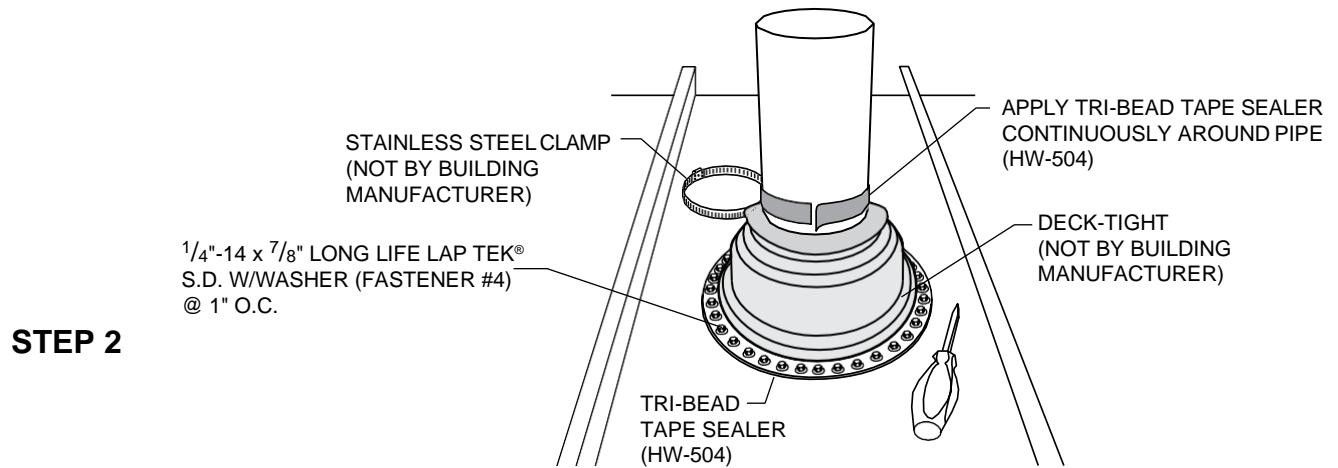
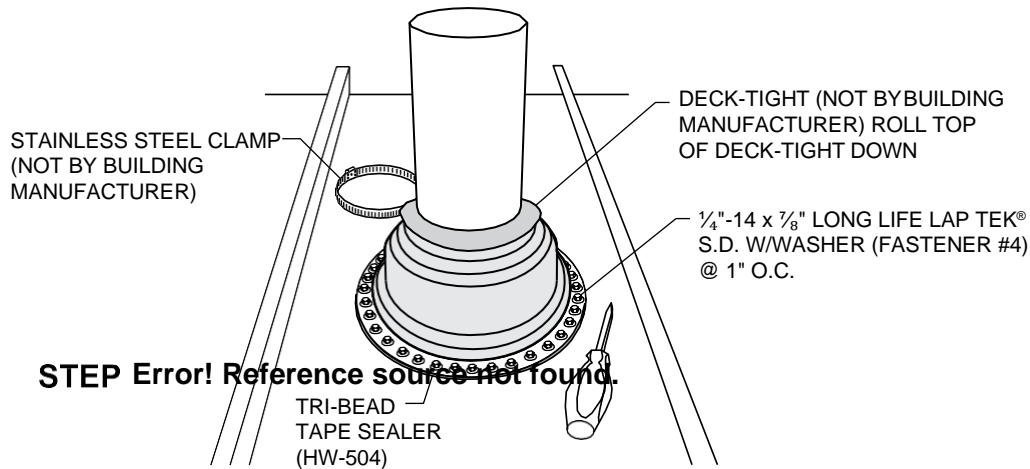

DETAILS

OPEN FRAMING HIGH FIXED EAVE WITH SCULPTURED GUTTER

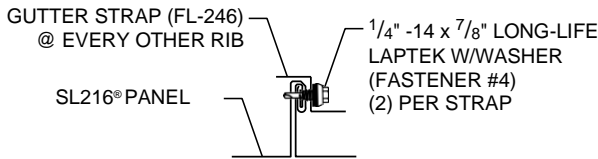

GUTTER STRAP ATTACHMENT

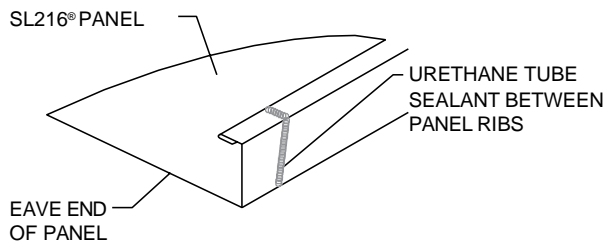

EAVE SEALANT

URETHANE SEALANT MUST COME IN CONTACT WITH TAPE SEALER TO FORM A WEATHERTIGHT SEAL

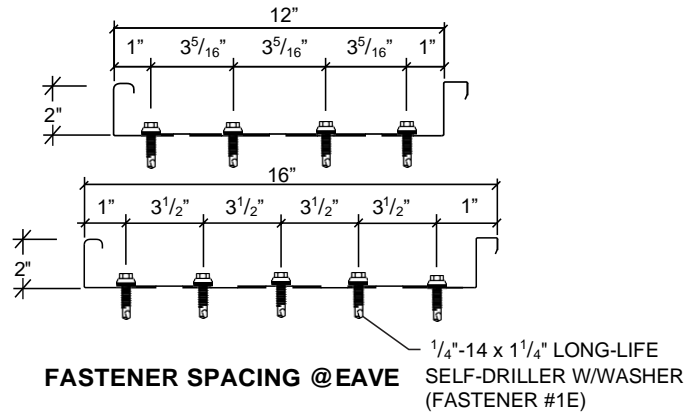

FASTENER SPACING @ EAVE

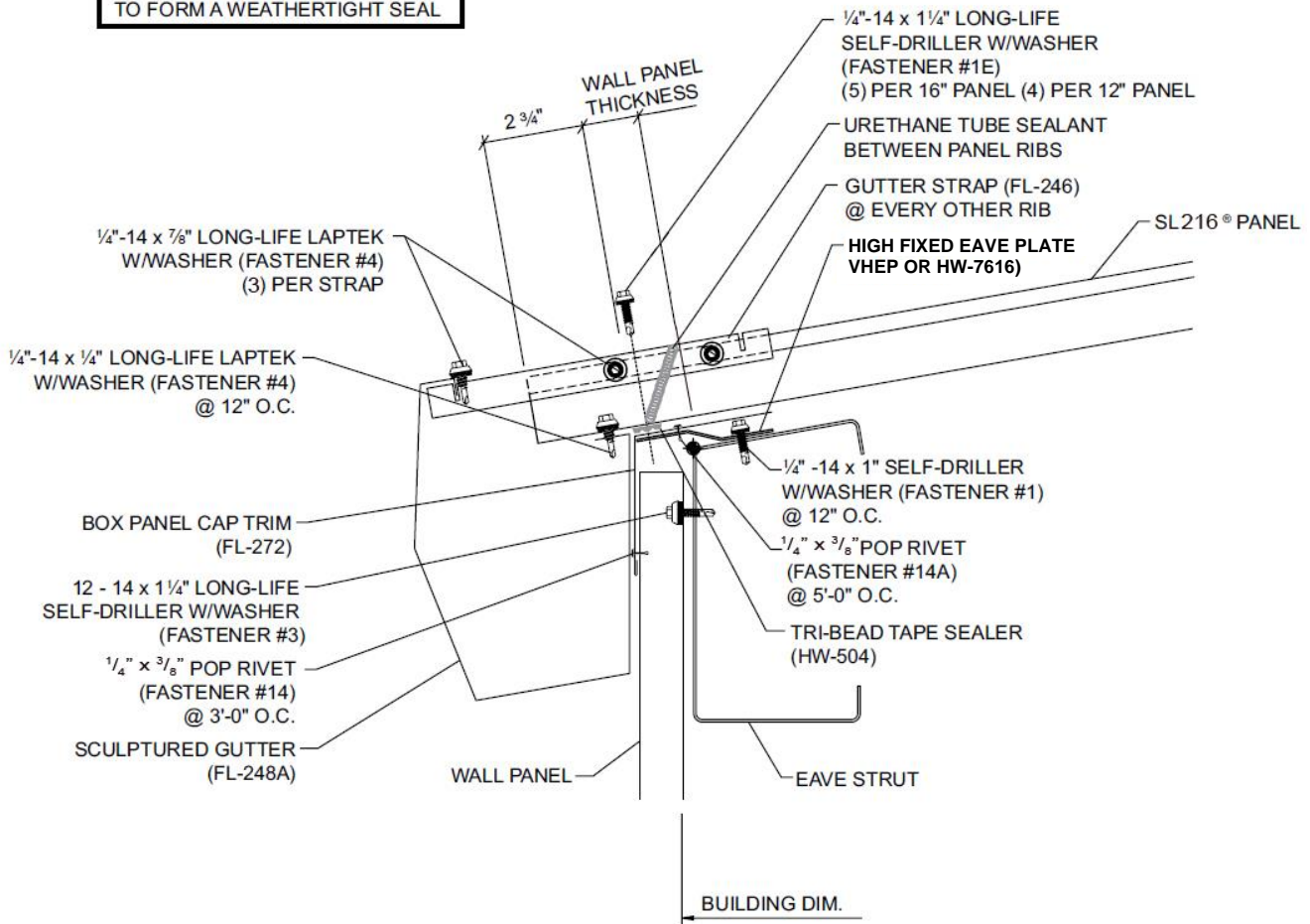

DETAILS

OPEN FRAMING

FIXED EAVE WITH SCULPTURED EAVE TRIM

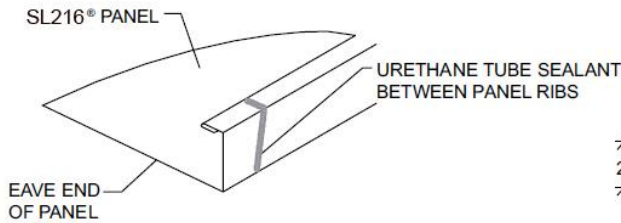

EAVE SEALANT DETAIL

URETHANE SEALANT MUST COME IN CONTACT WITH TAPE SEALER TO FORM A WEATHERTIGHT SEAL

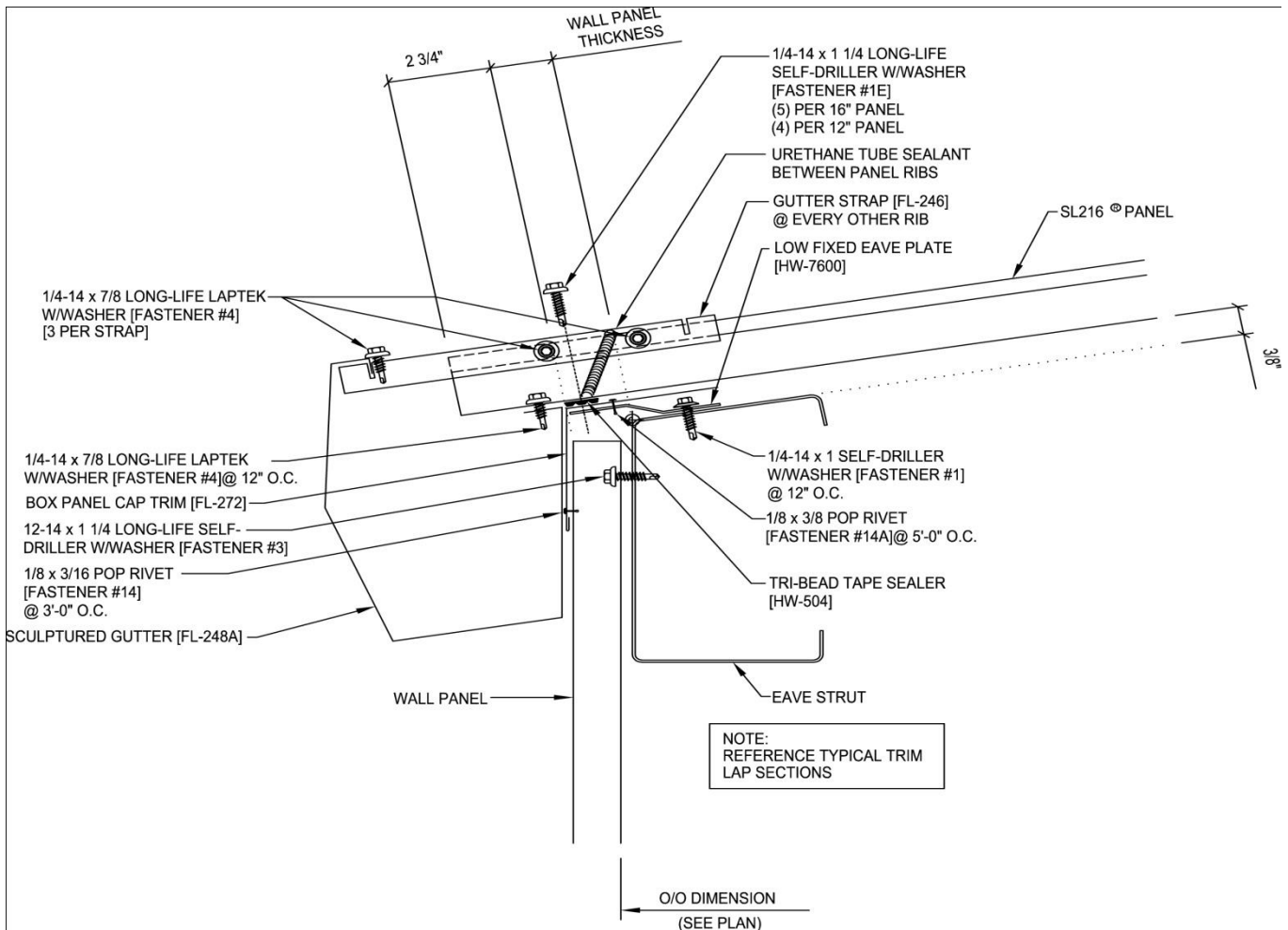
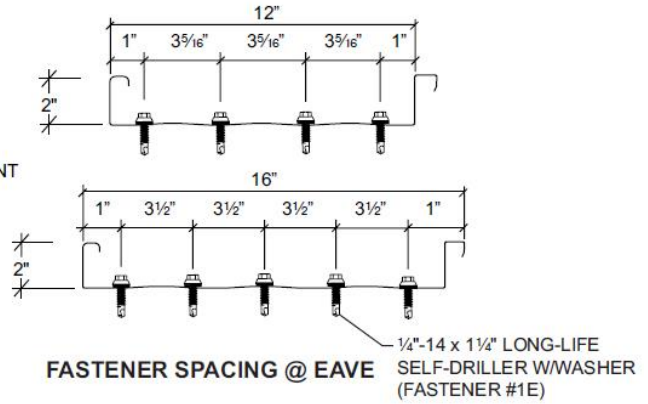

DETAILS

OPEN FRAMING FIXED EAVE WITH BOX EAVE TRIM

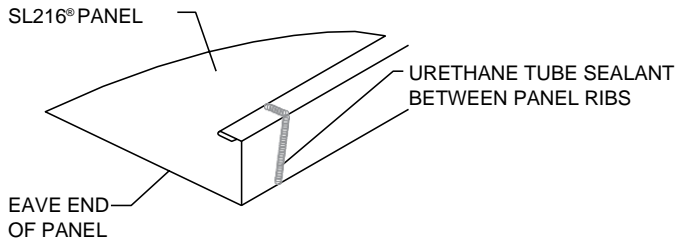

EAVE SEALANT DETAIL

URETHANE SEALANT MUST COME IN CONTACT WITH TAPE SEALER TO FORM A WEATHERTIGHT SEAL

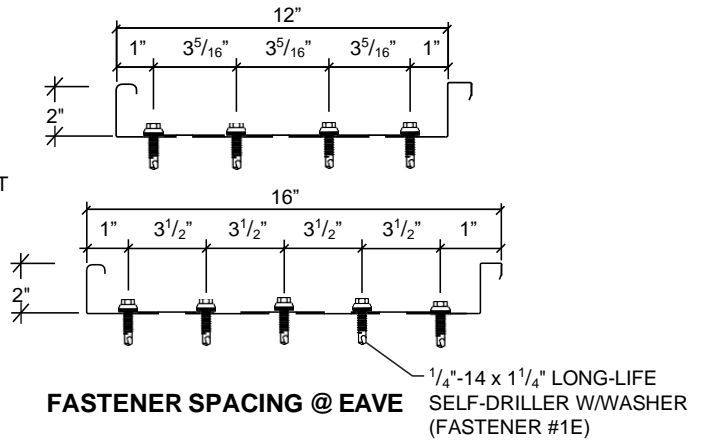

FASTENER SPACING @ EAVE

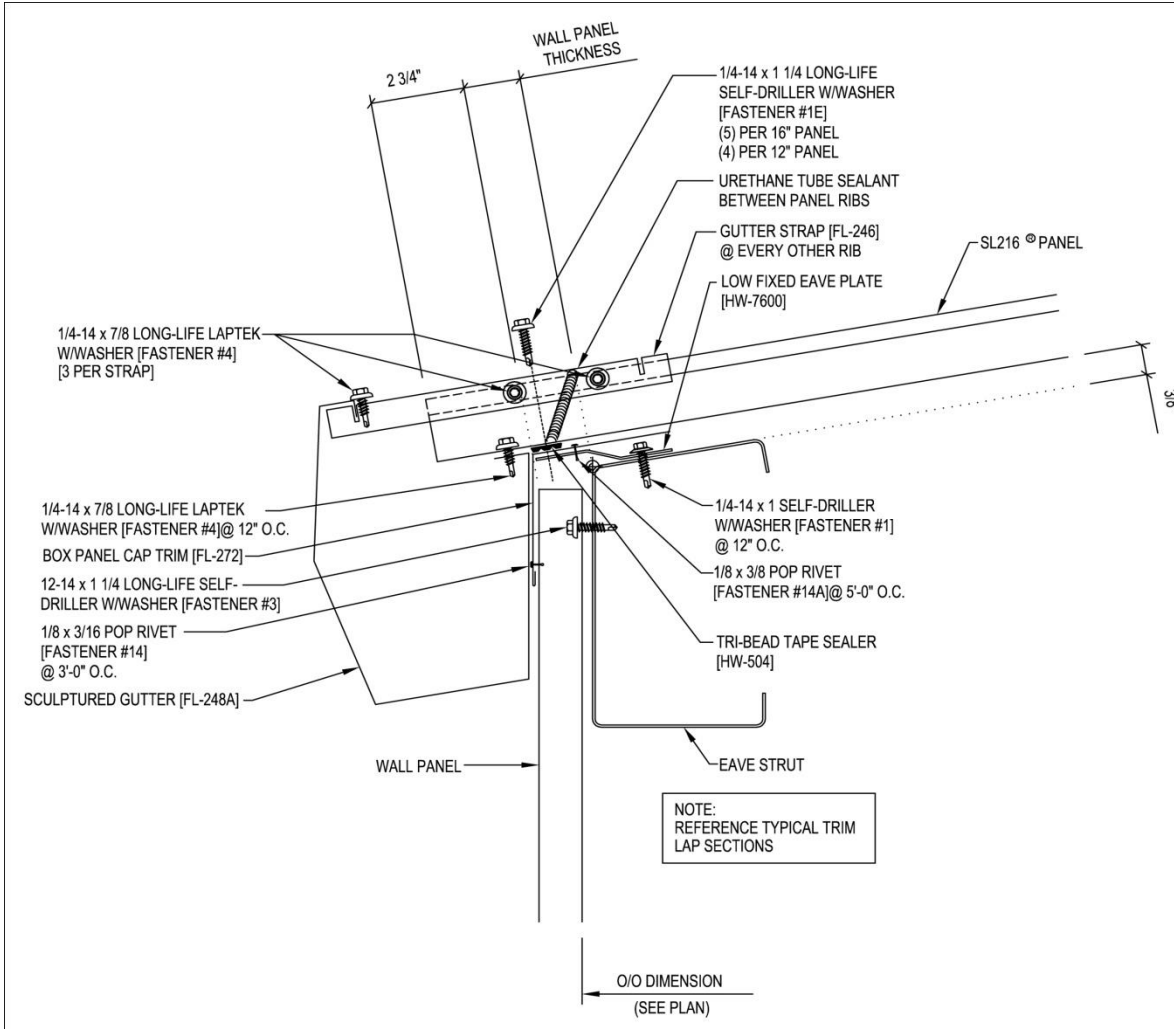

DETAILS

OPEN FRAMING FLOATING RIDGE

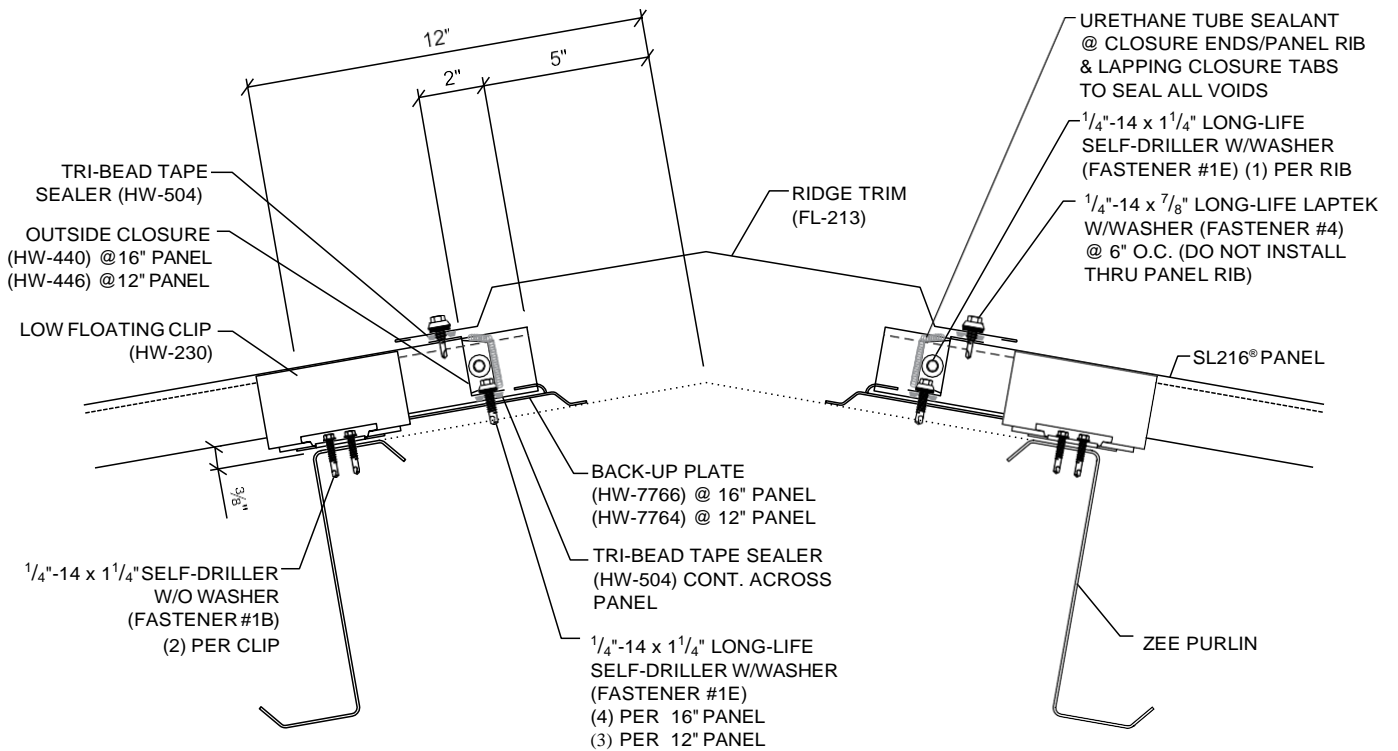

DETAILS

OPEN FRAMING FLOATING VENTED RIDGE

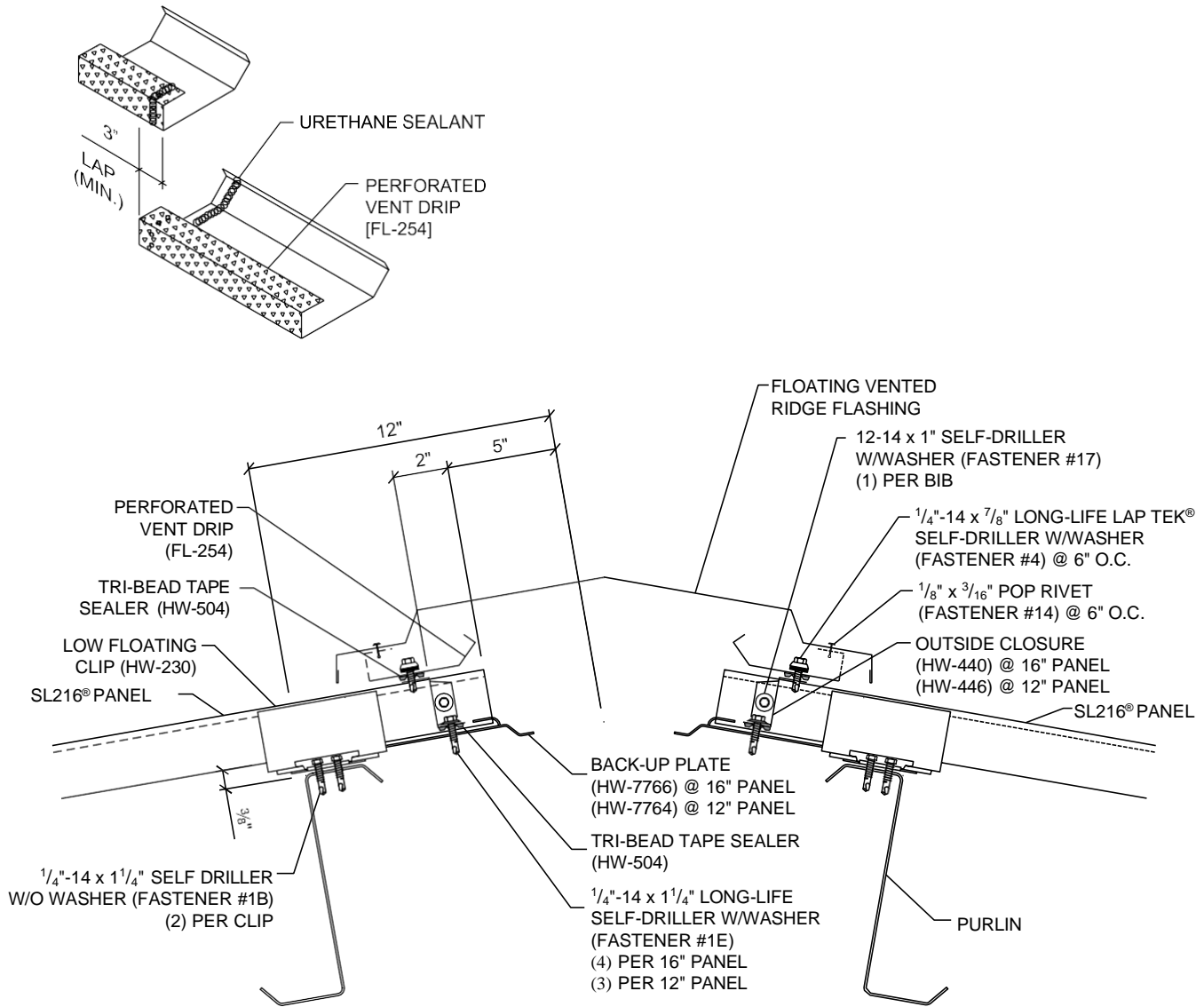

DETAILS

OPEN FRAMING FIXED VENTED EAVE

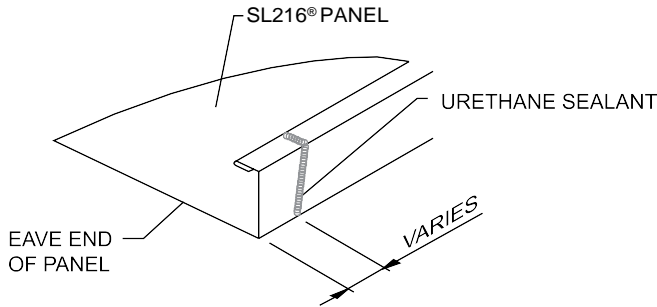

URETHANE SEALANT MUST COME IN CONTACT WITH TAPE SEALER TO FORM A WEATHERTIGHT SEAL

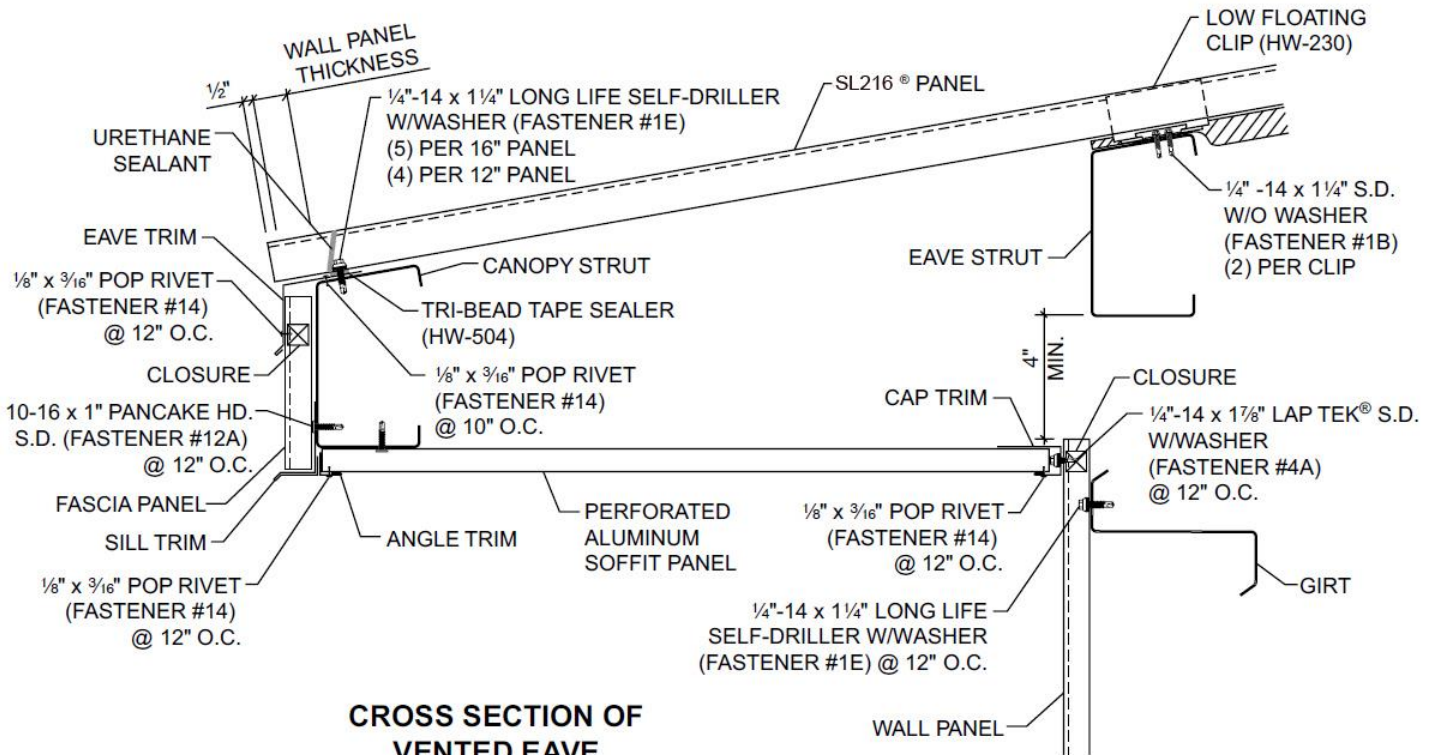

**CROSS SECTION OF
VENTED EAVE
(OVERHANG MAXIMUM 2'-0")**

DETAILS

OPEN FRAMING SCULPTURED RAKE

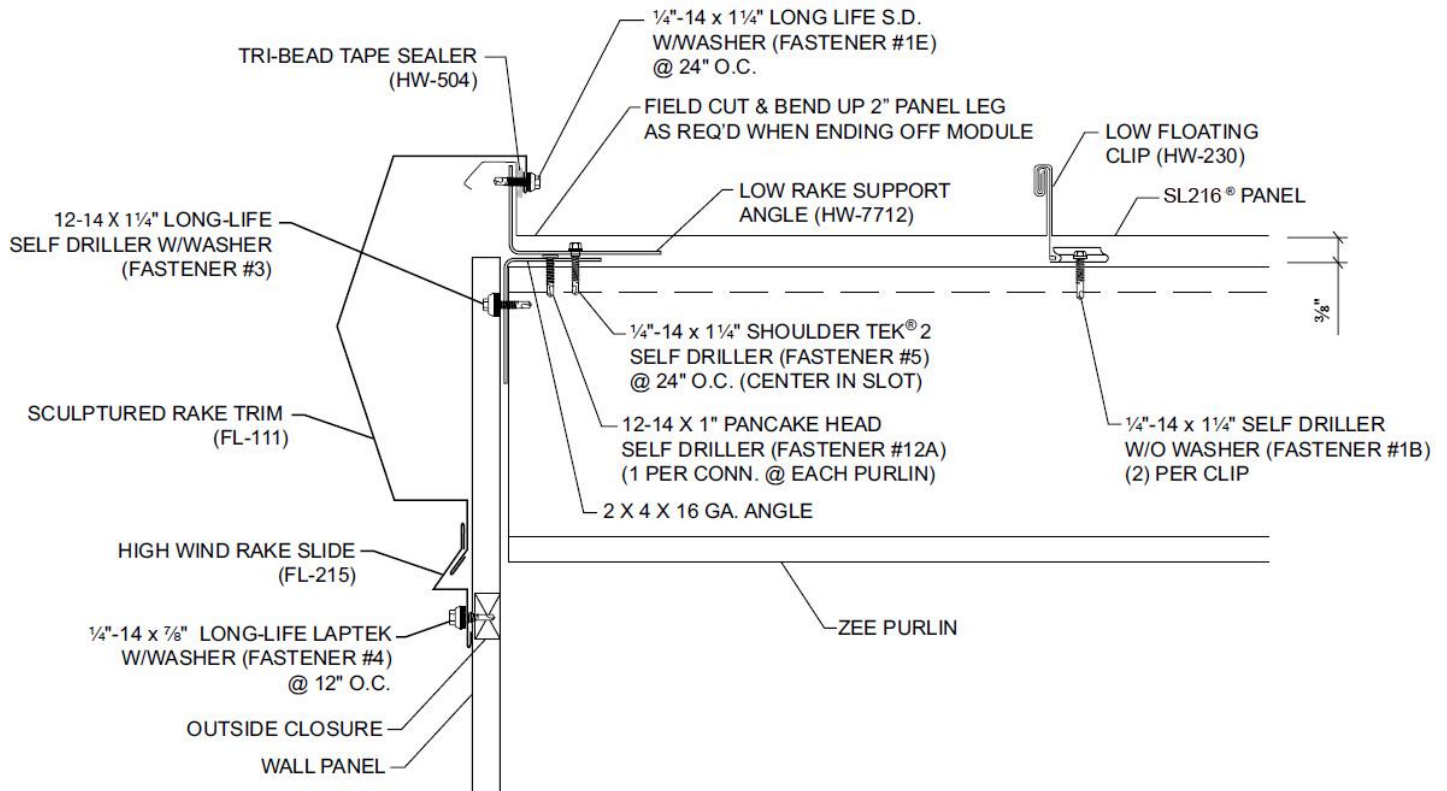

DETAILS

OPEN FRAMING SCULPTURED RAKE WITH CLEAT

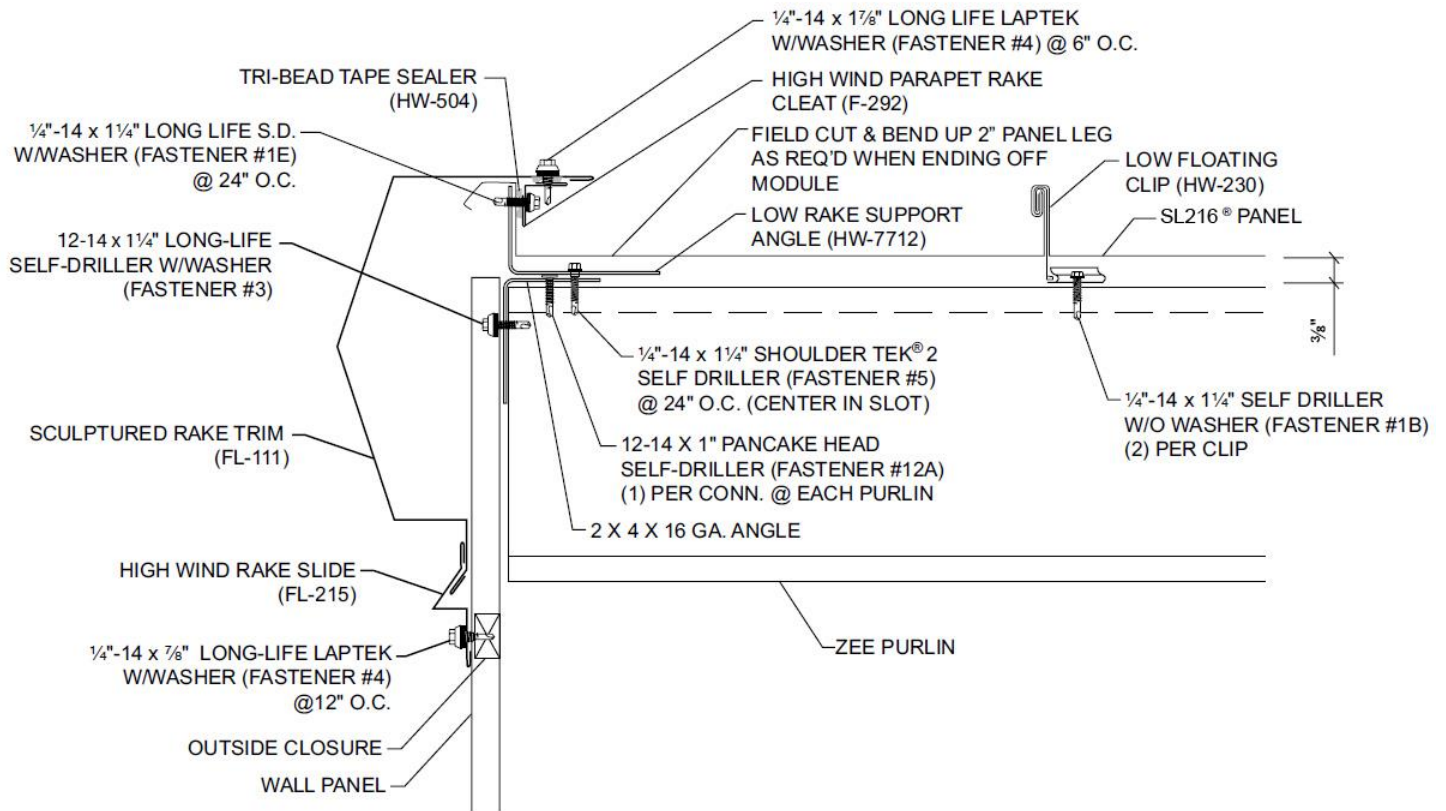

Error! Reference source not found.

OPEN FRAMING PARAPET RAKE

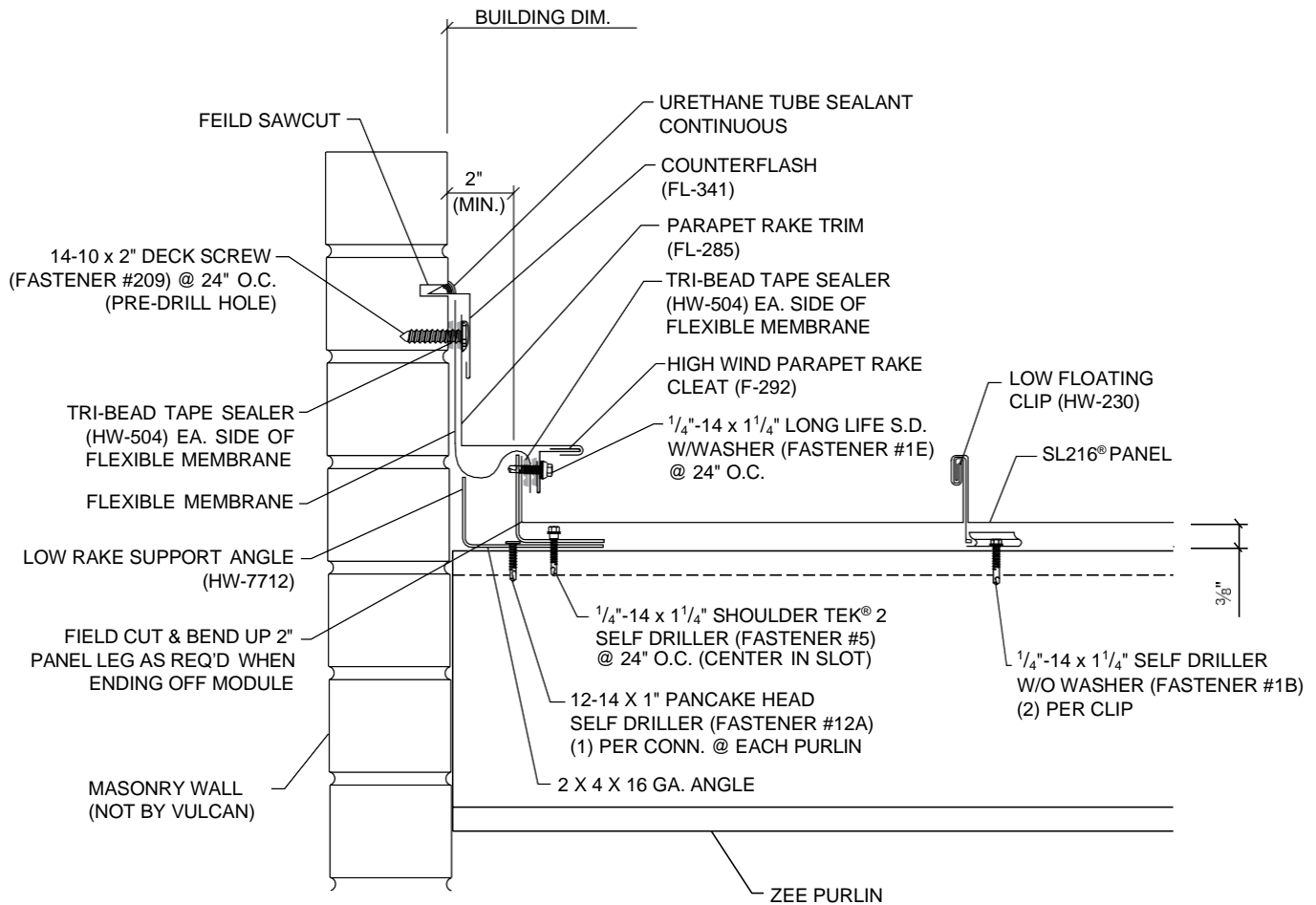

DETAILS

OPEN FRAMING

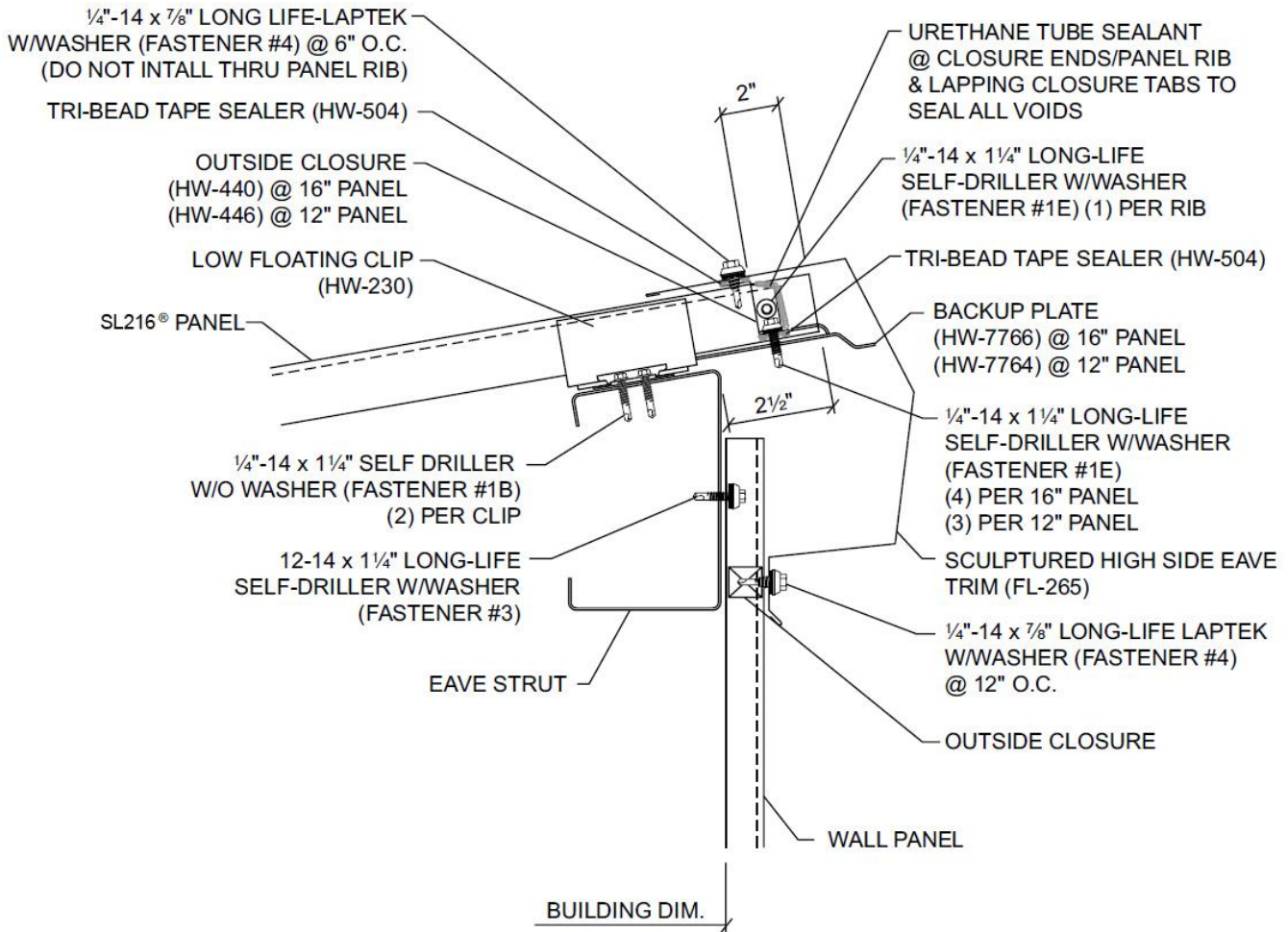
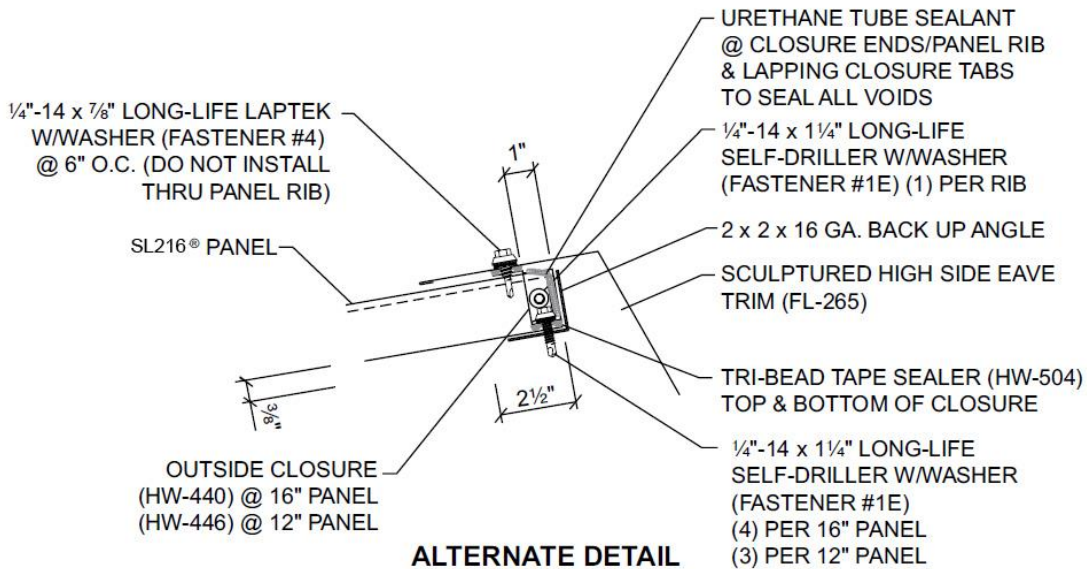

DETAILS

OPEN FRAMING

PARAPET FLOATING HIGH SIDE EAVE

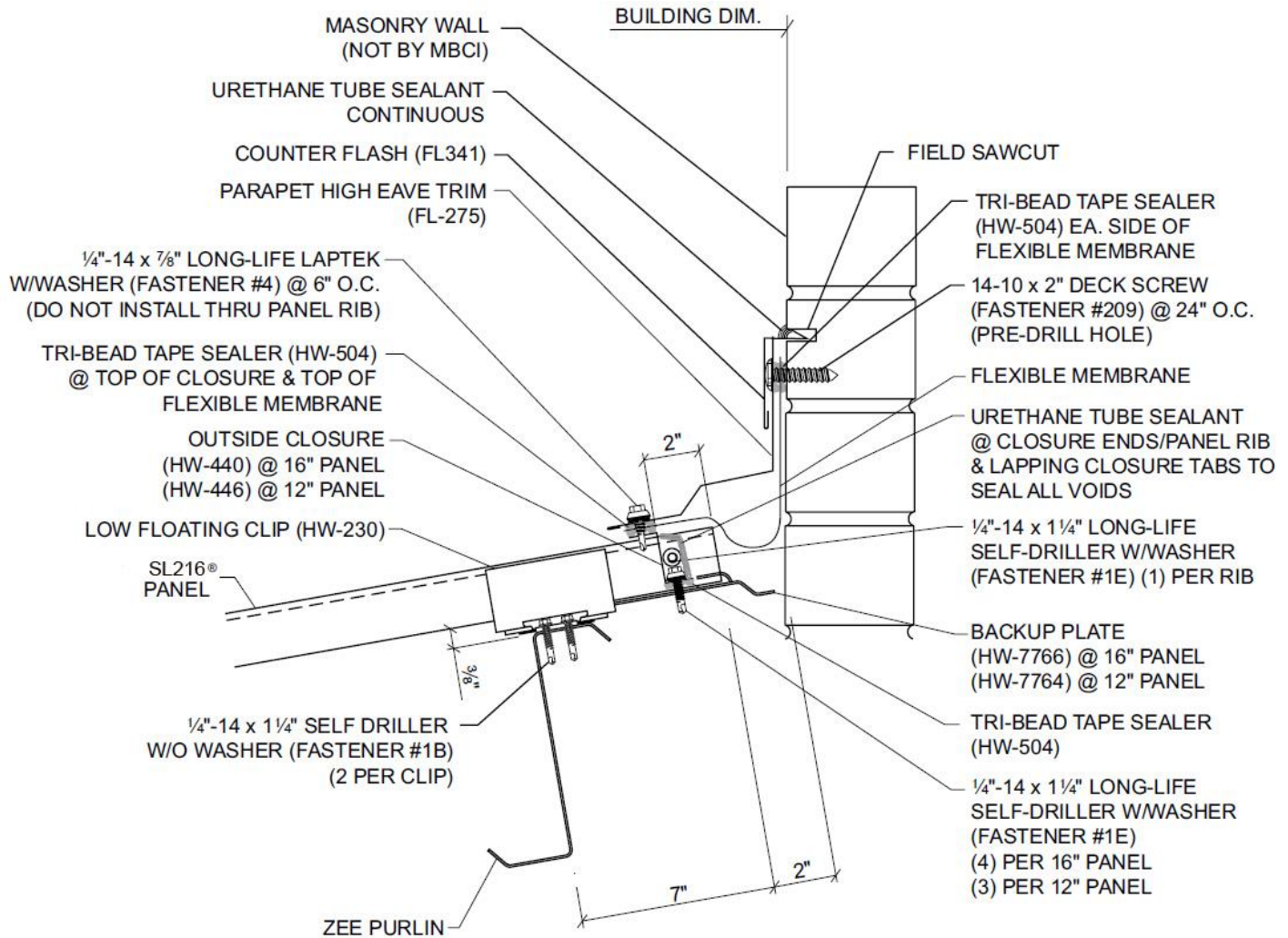

DETAILS

OPEN FRAMING FIXED VALLEY

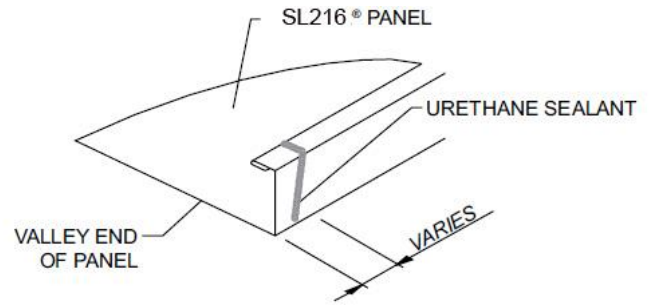
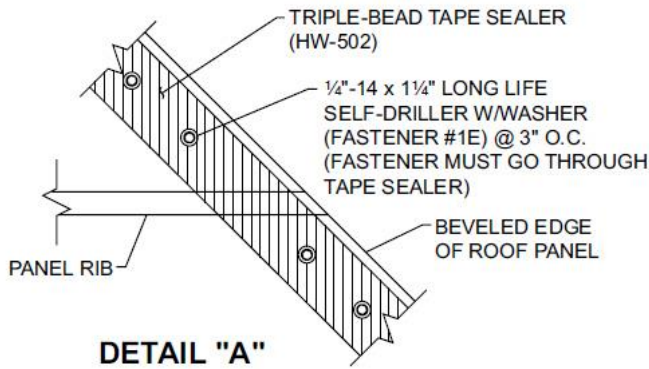

URETHANE SEALANT MUST COME IN CONTACT WITH TAPE SEALER TO FORM A WEATHERTIGHT SEAL

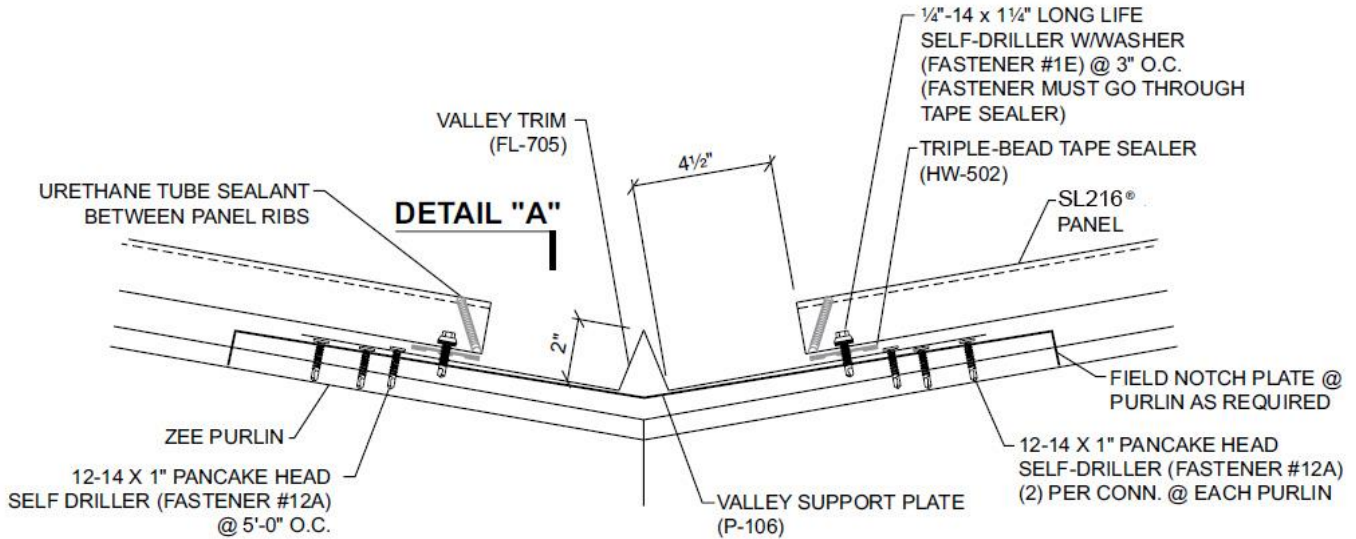

DETAILS

OPEN FRAMING

FLOATING HIP

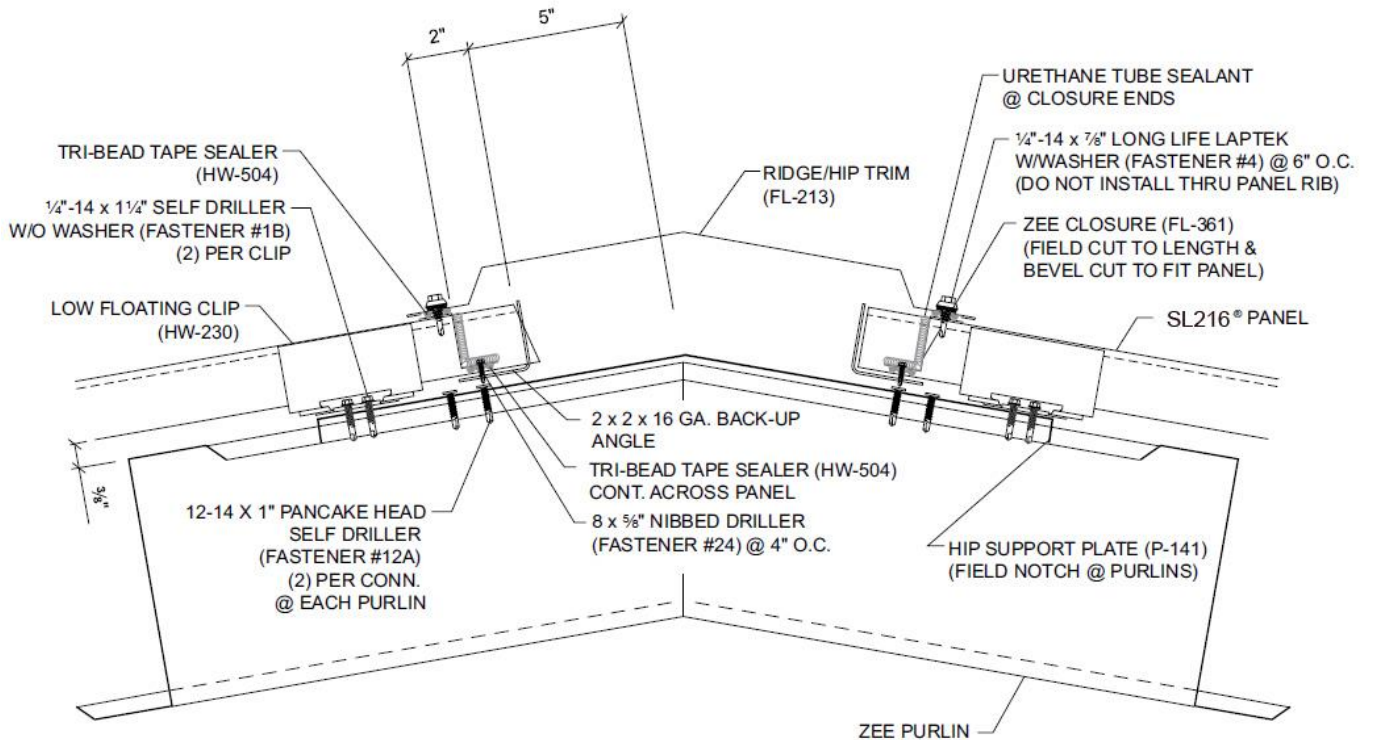

DETAILS

FIELD HEMMING PANEL END

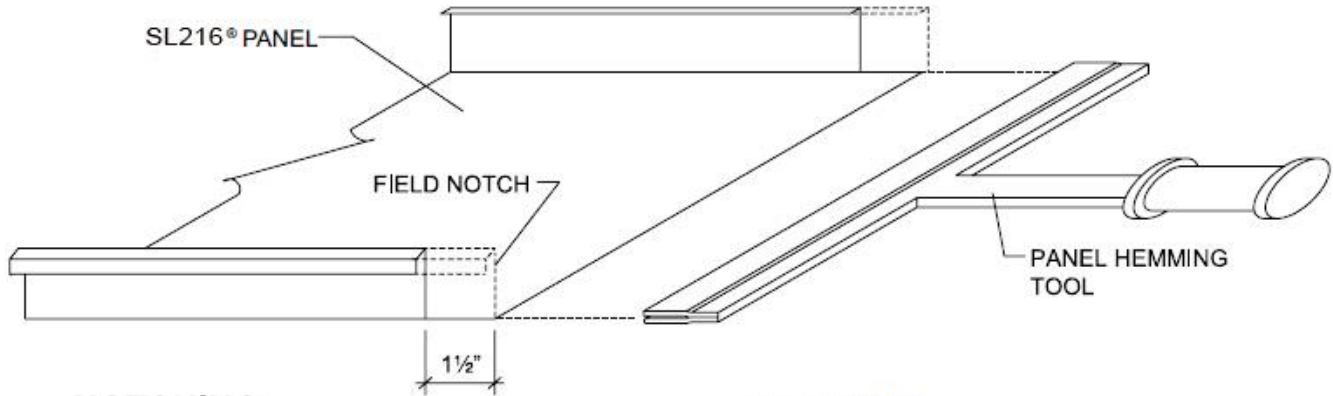

NOTCHING PANEL END

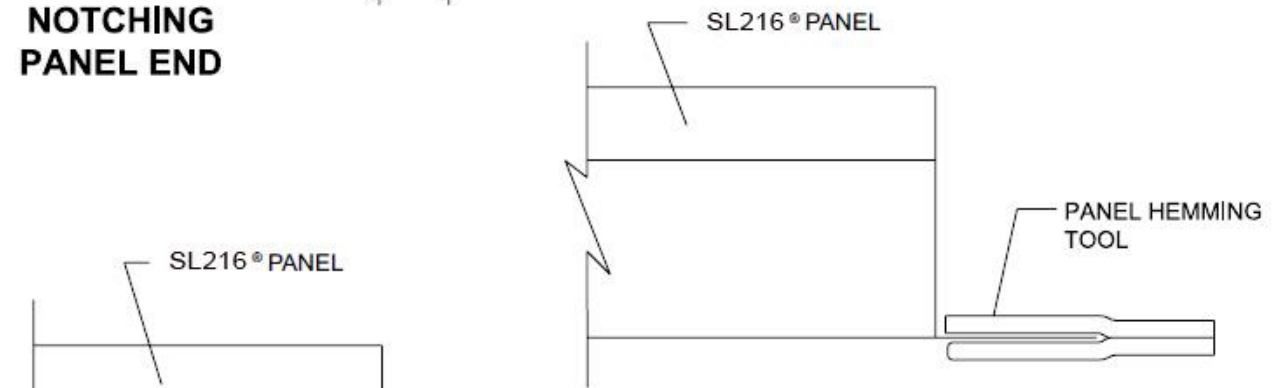

ENGAGING HEMMING TOOL

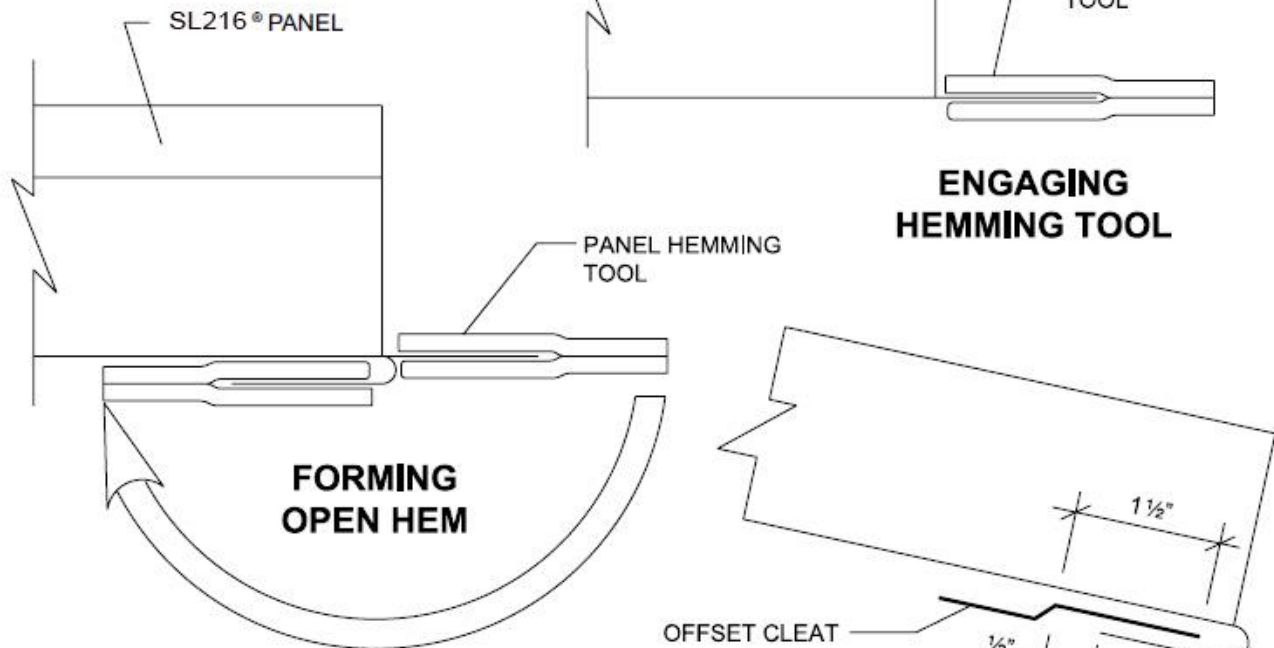

PANEL ENGAGEMENT

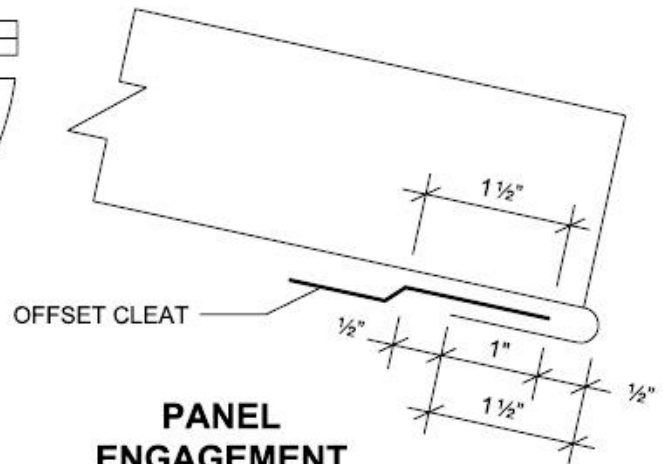

DETAILS

WOOD DECK FLOATING ENDLAP

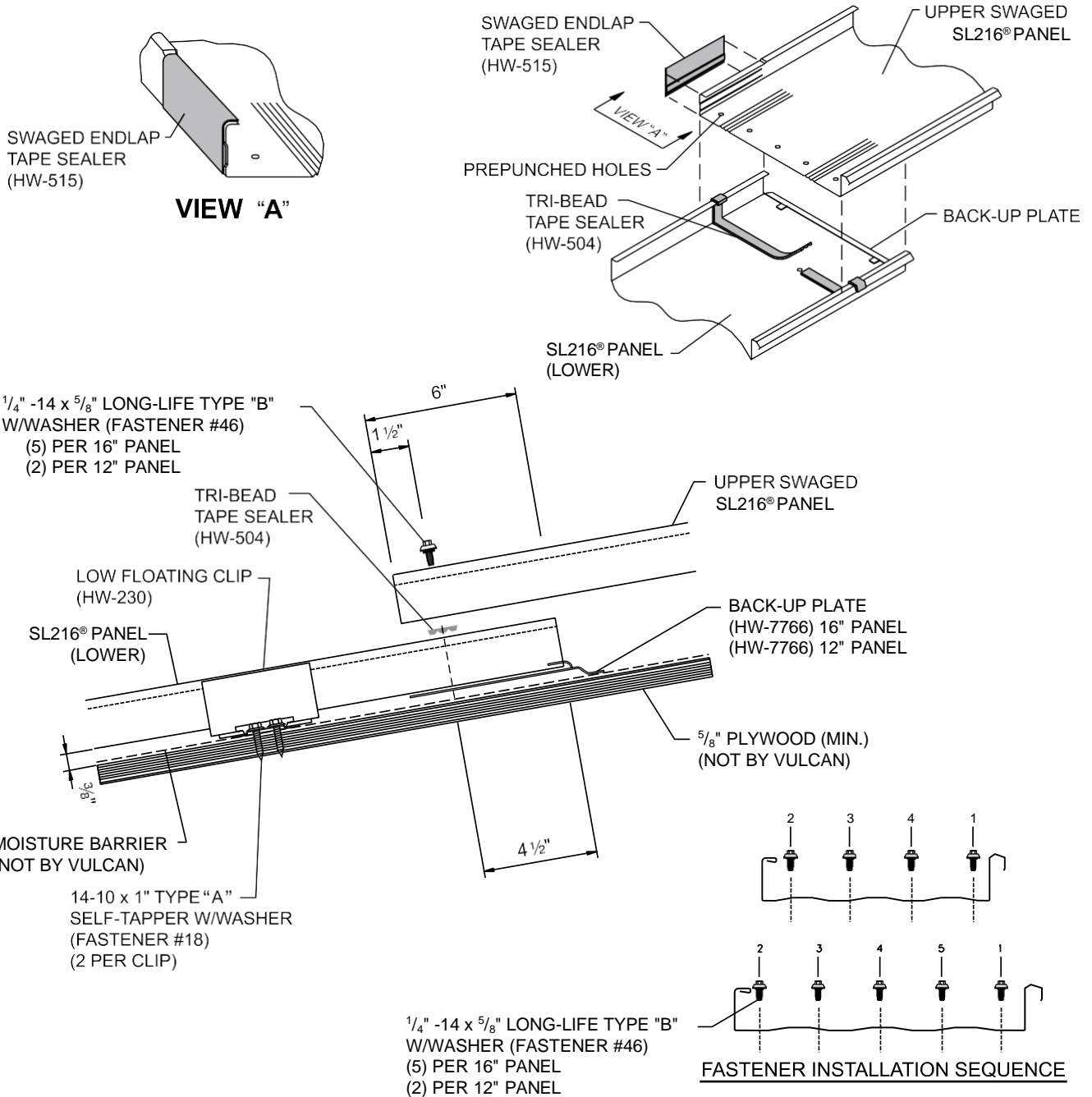

DETAILS

WOOD DECK FLOATING EAVE WITH BOX GUTTER

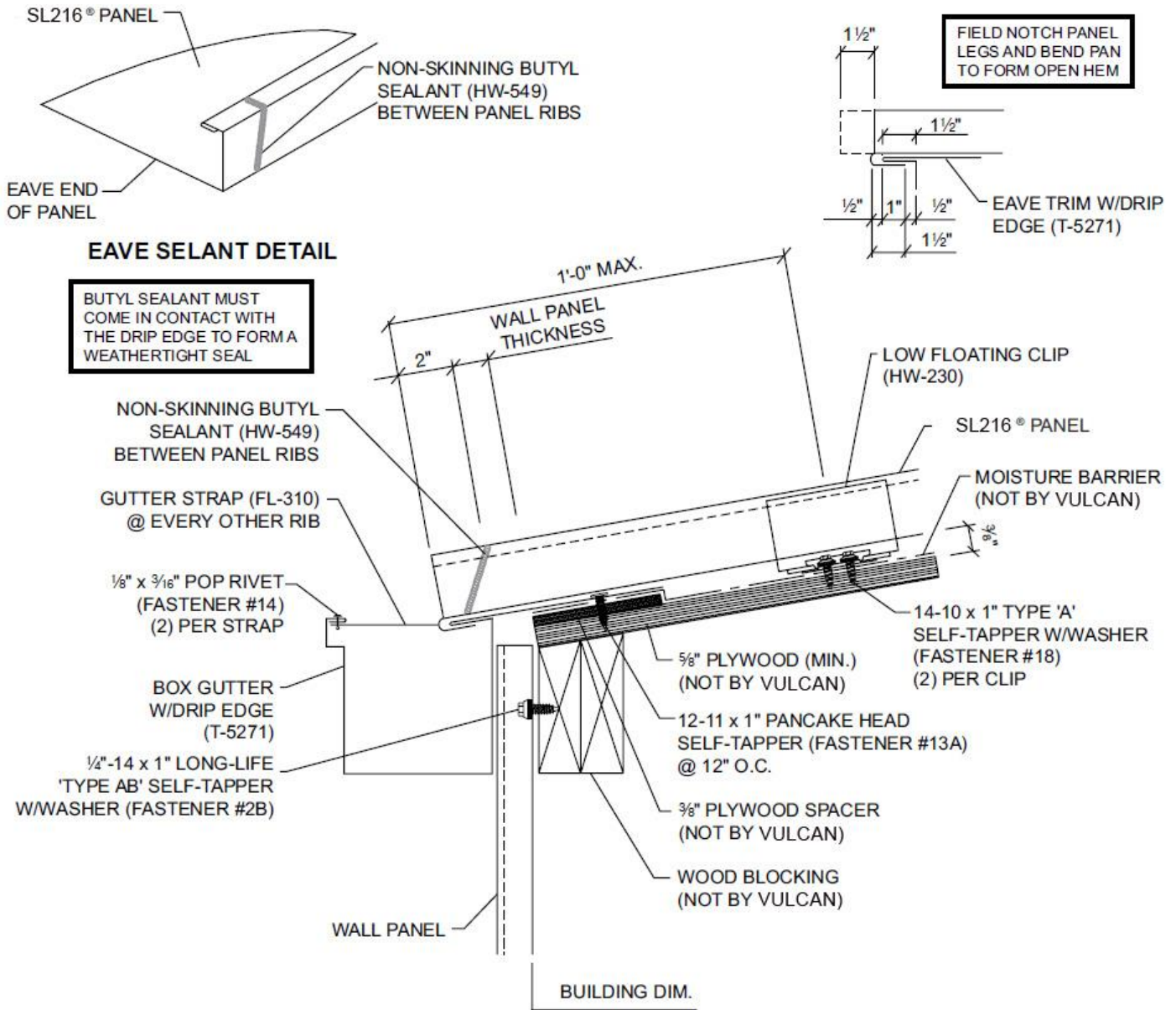

NOTE : DO NOT USE THIS DETAIL ON ROOF SLOPES LESS THAN 3 : 12

DETAILS

WOOD DECK

FLOATING EAVE WITH EAVE TRIM WITH EXTENDED DRIP EDGE

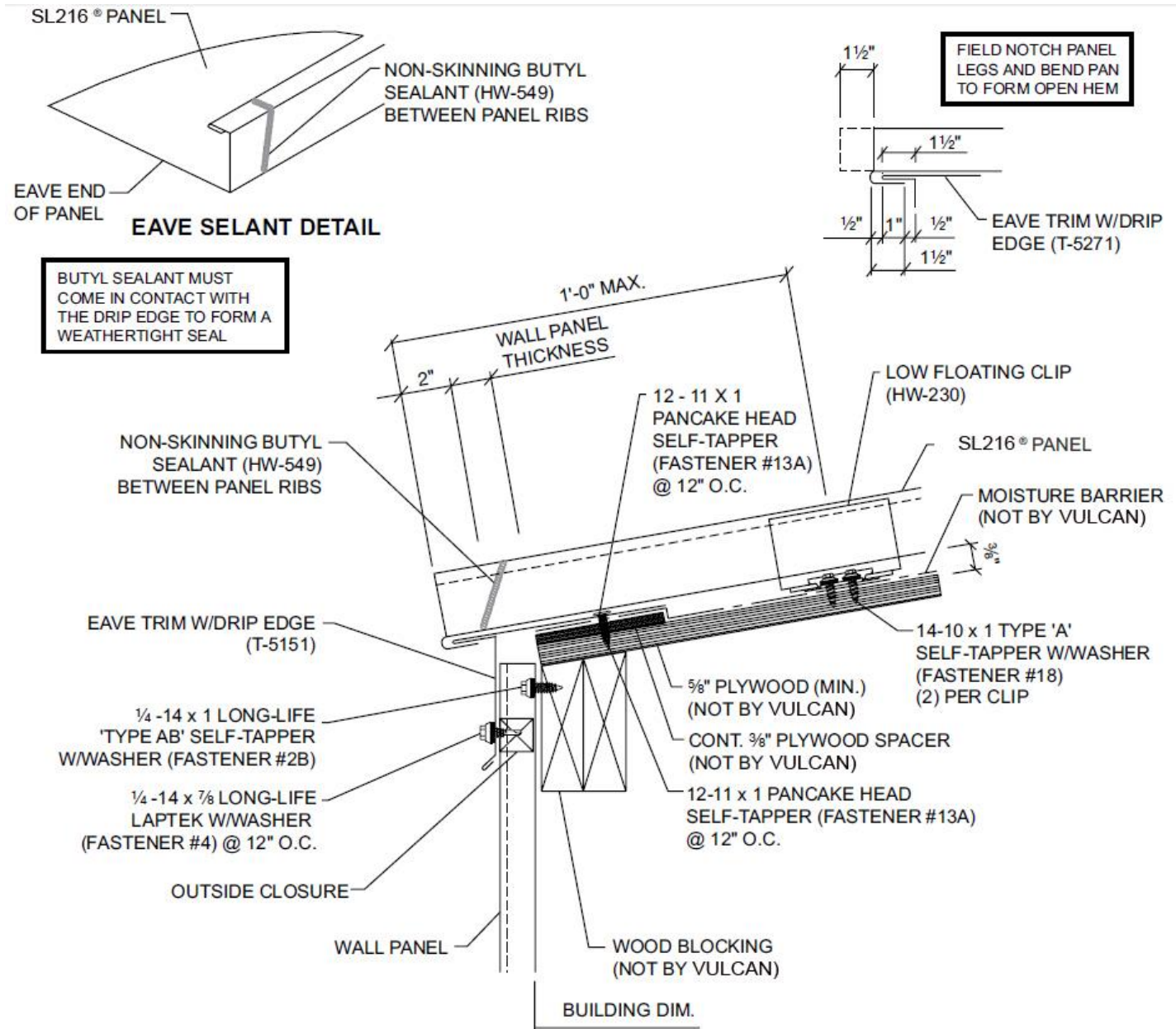

NOTE : DO NOT USE THIS DETAIL ON ROOD SLOPES LESS THAN 3 : 12

DETAILS

WOOD DECK FIXED RIDGE

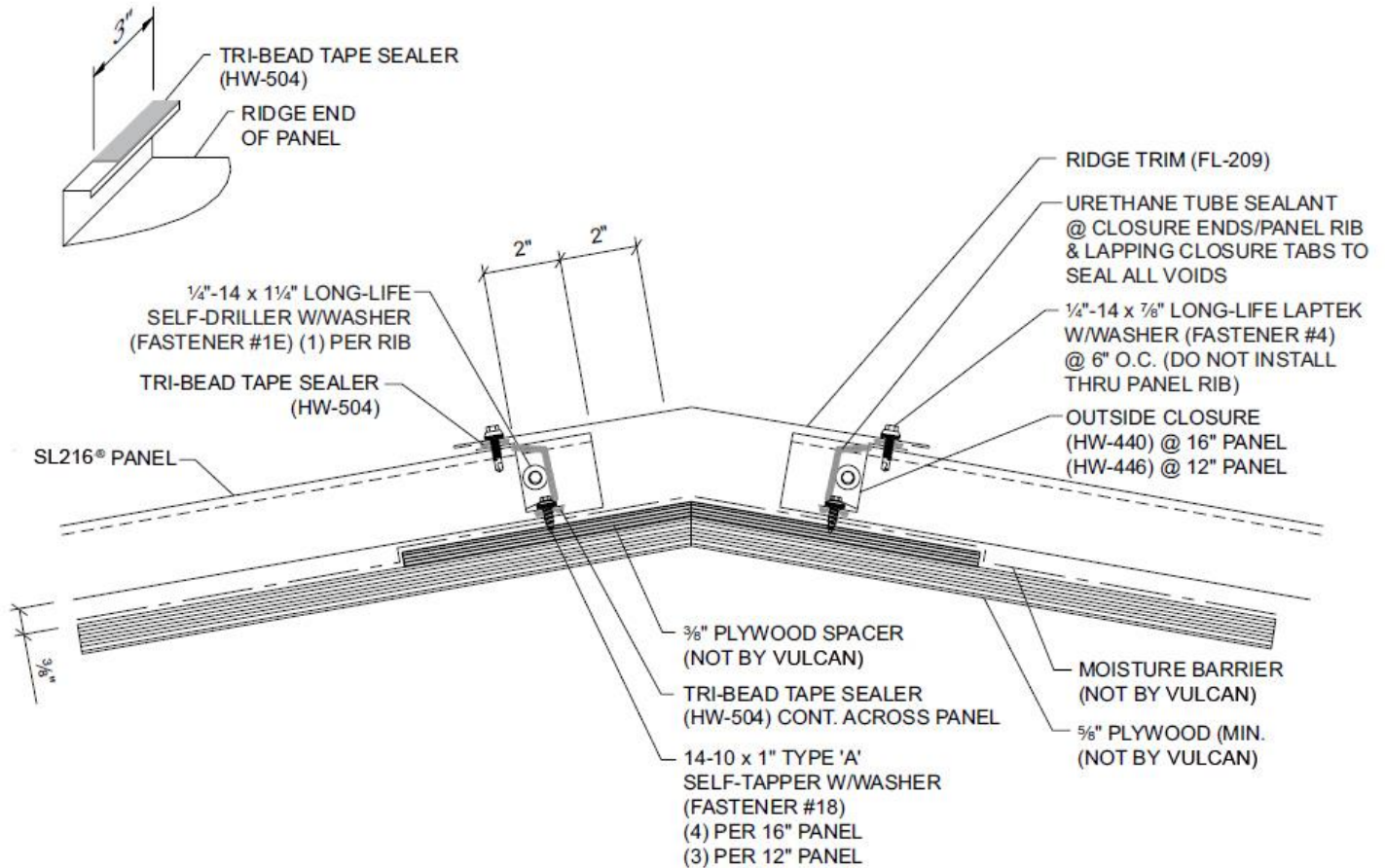

DETAILS

WOOD DECK FIXED VENTED RIDGE

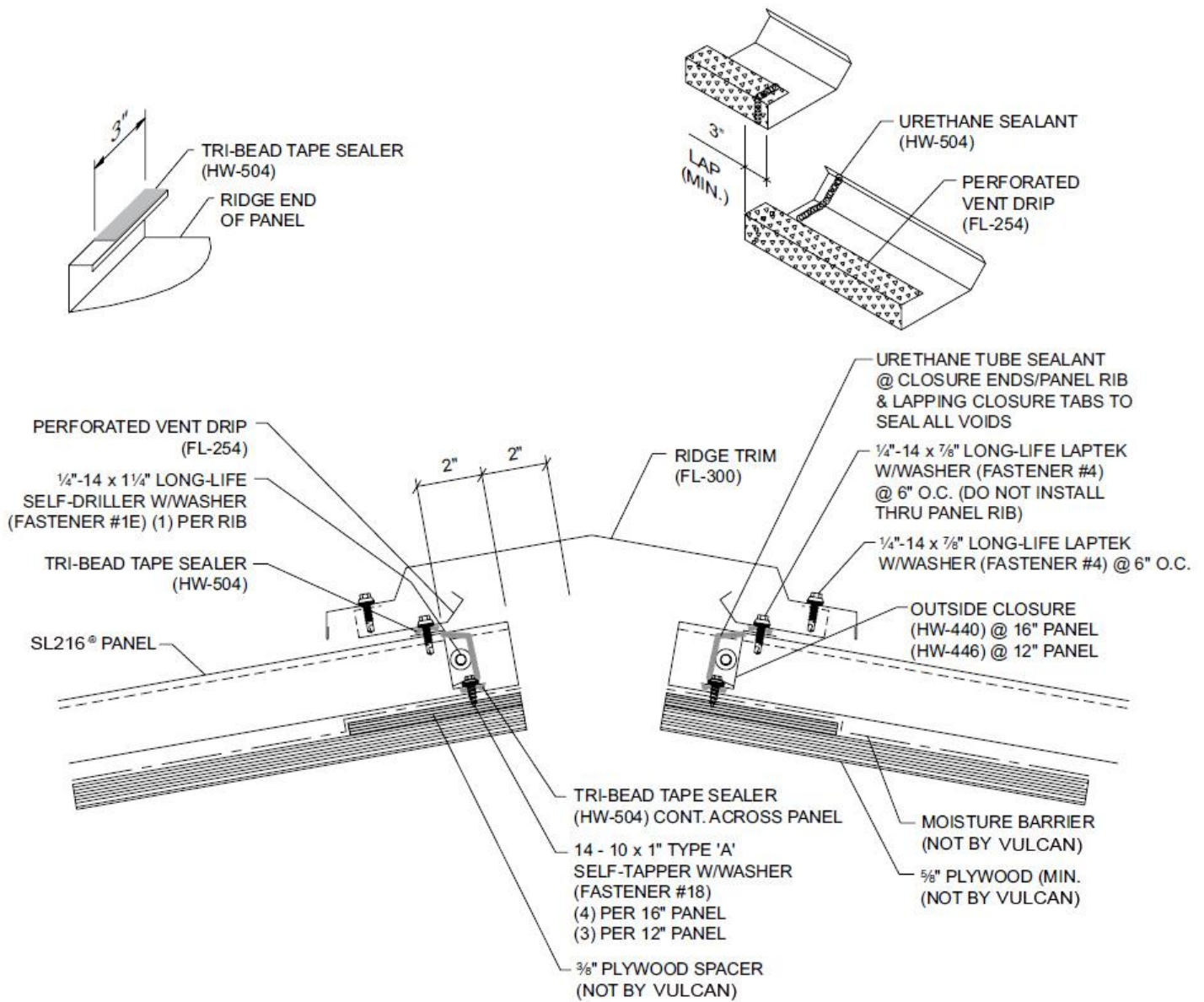

DETAILS

WOOD DECK BOX RAKE

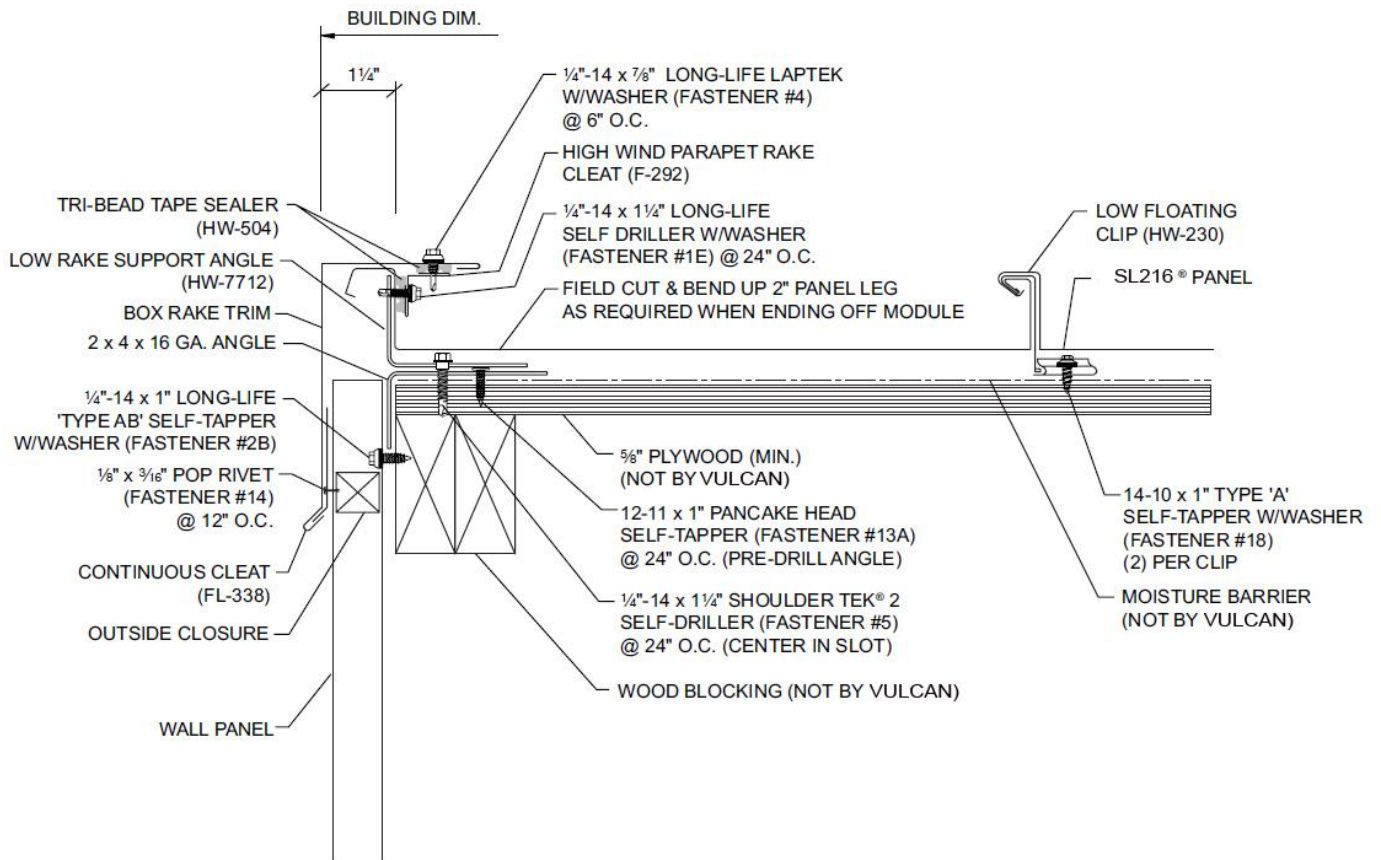

DETAILS

WOOD DECK PARAPET RAKE

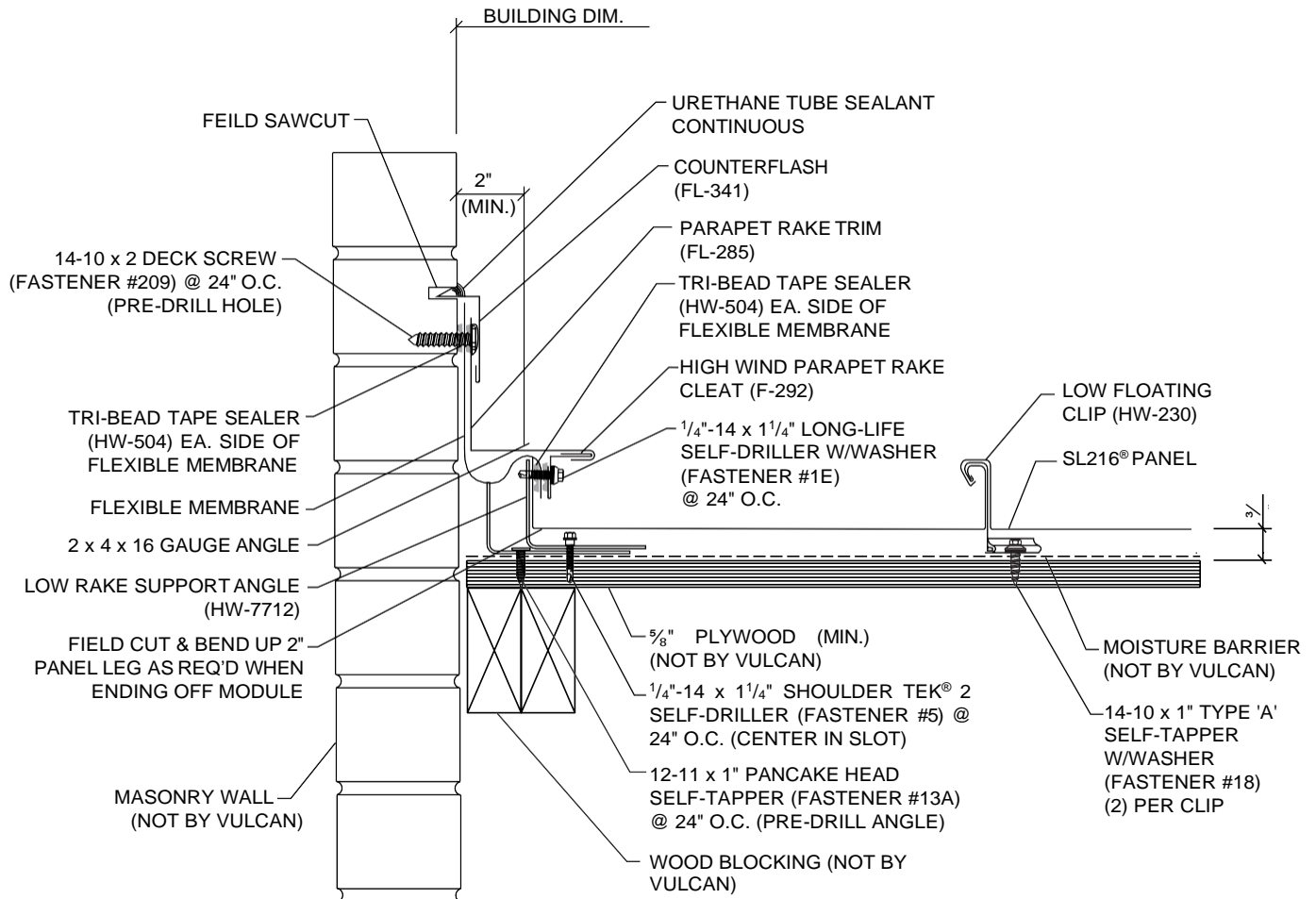

DETAILS

WOOD DECK FIXED BOX HIGH SIDE EAVE

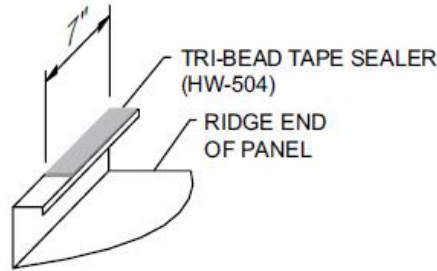

HIGH EAVE SEALANT DETAIL

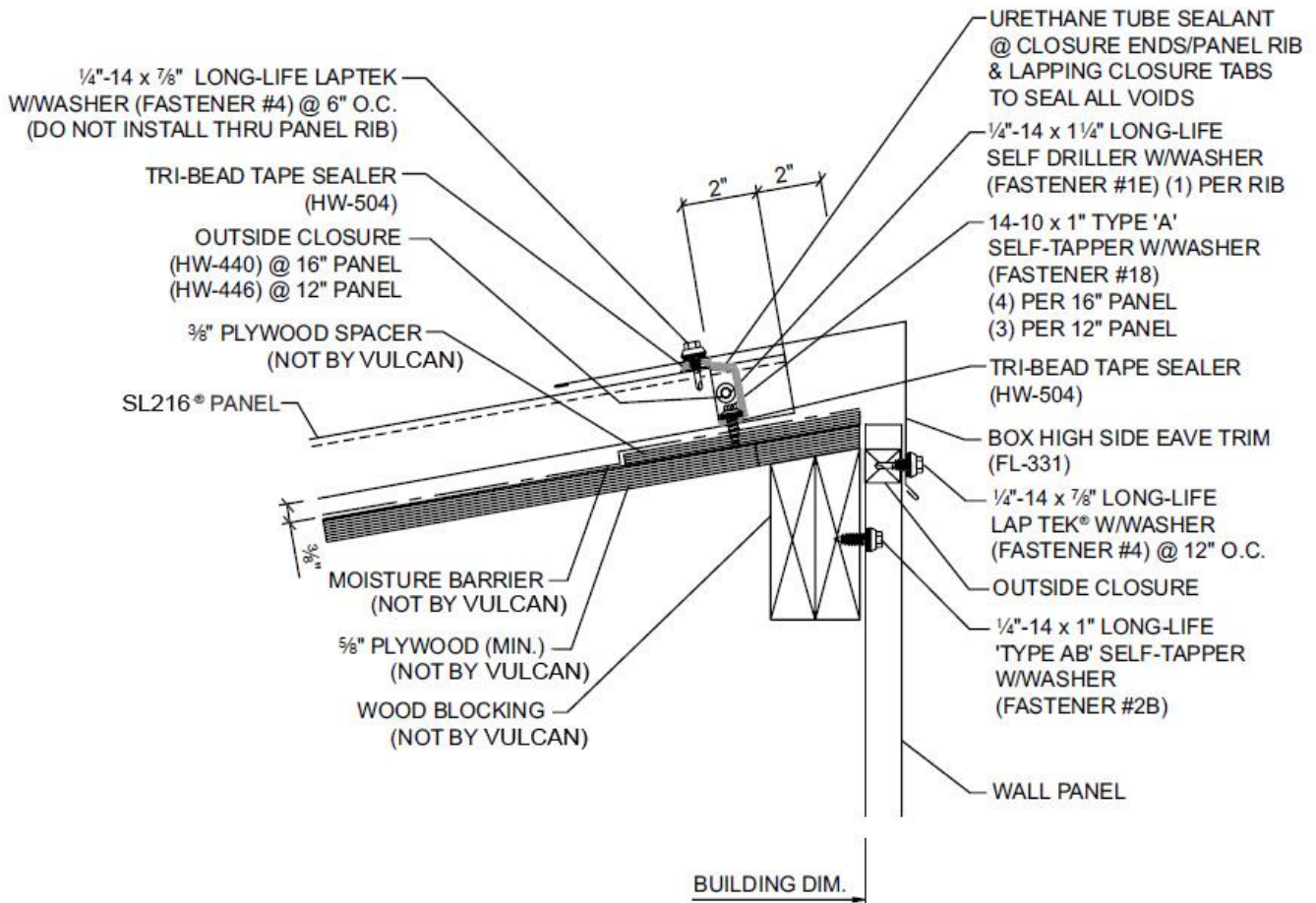

DETAILS

WOOD DECK PARAPET FIXED HIGH SIDE EAVE

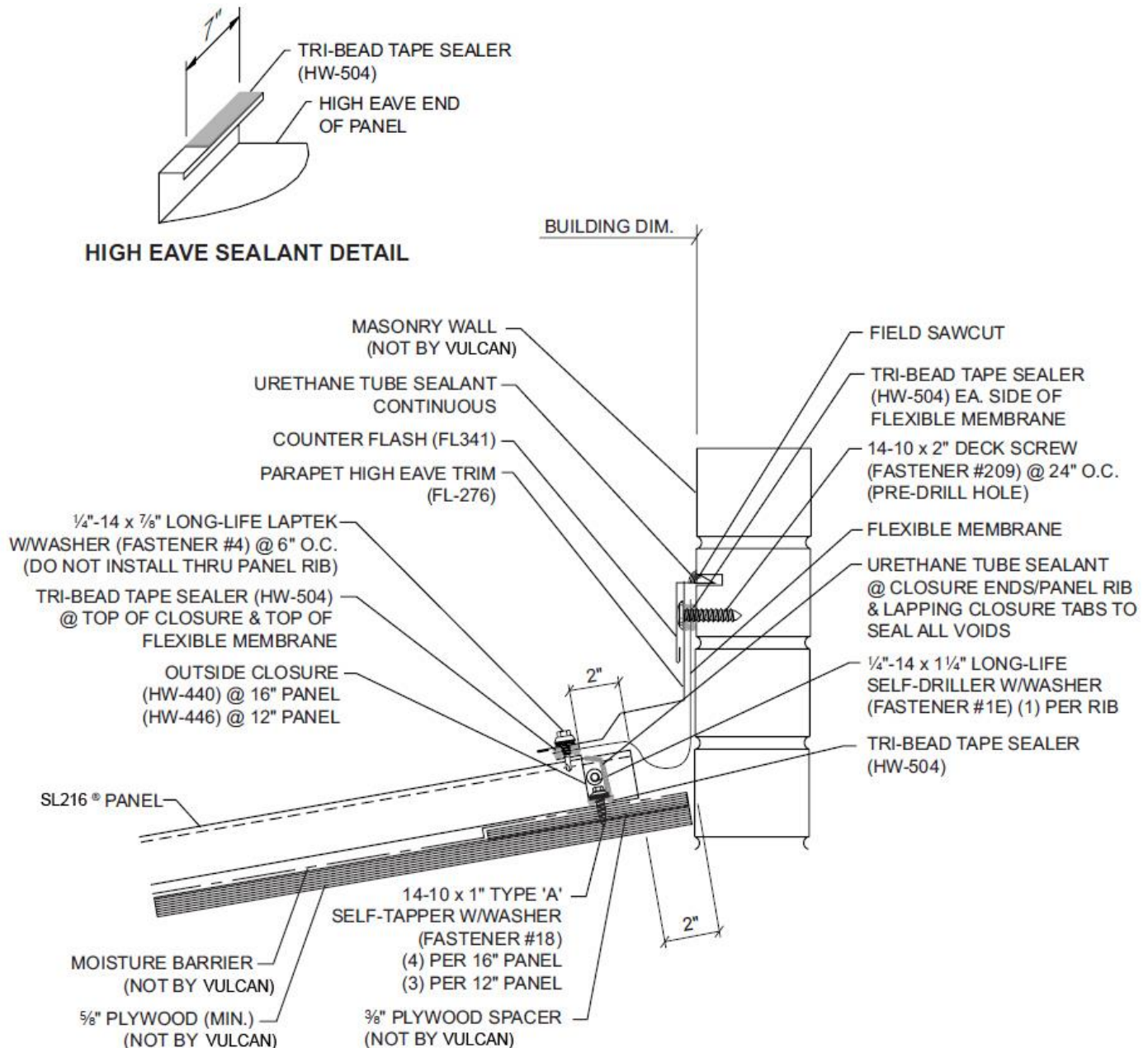

DETAILS

WOOD DECK FLOATING VALLEY

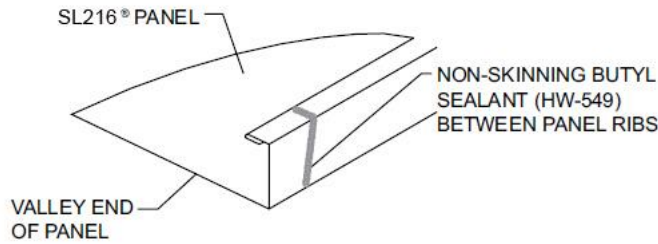

BUTYL SEALANT MUST COME IN CONTACT WITH THE OFFSET CLEAT TO FORM A WEATHERTIGHT SEAL

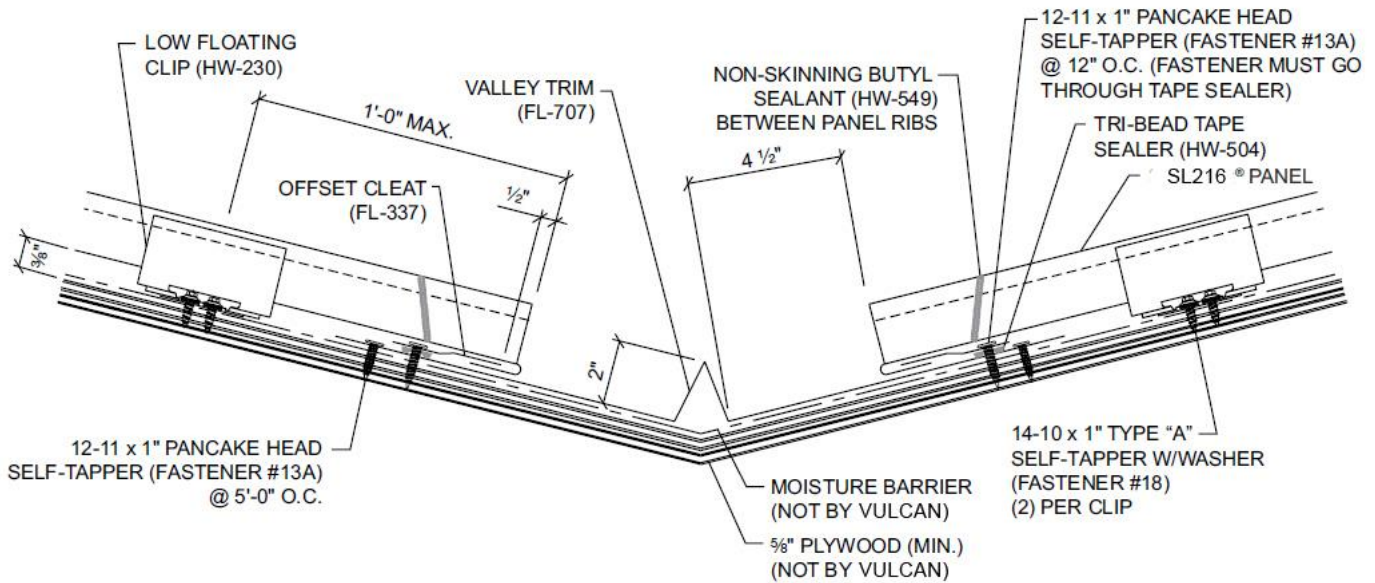
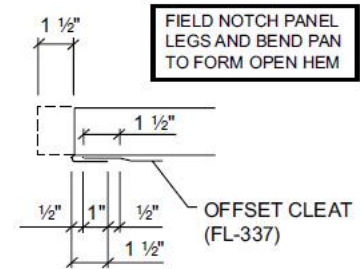

NOTE: DO NOT USE THIS DETAIL ON ROOF SLOPES LESS THAN 3:12

DETAILS

WOOD DECK FIXED HIP

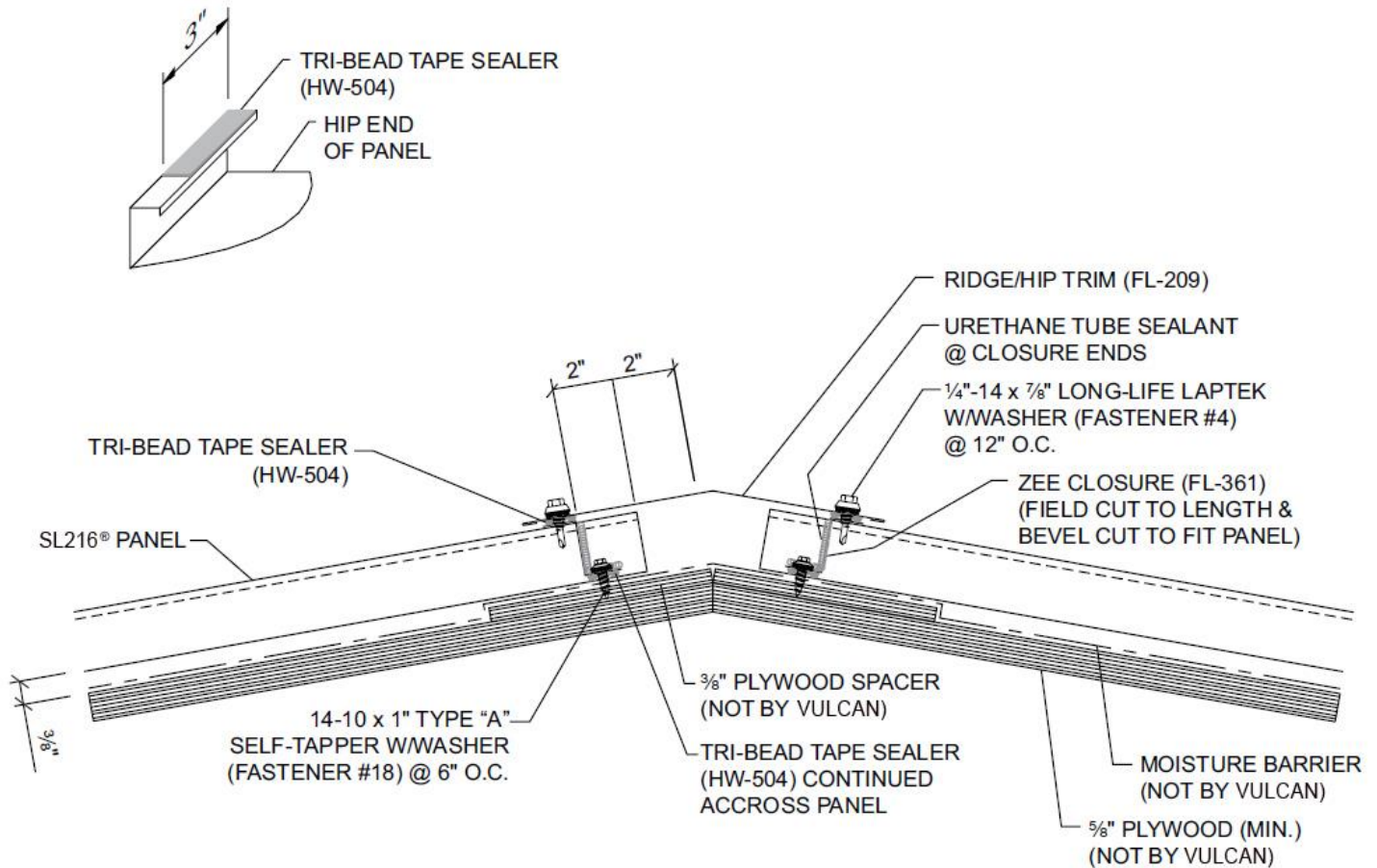

DETAILS

FLOATING ENDLAP RIGID INSULATION OVER METAL DECK

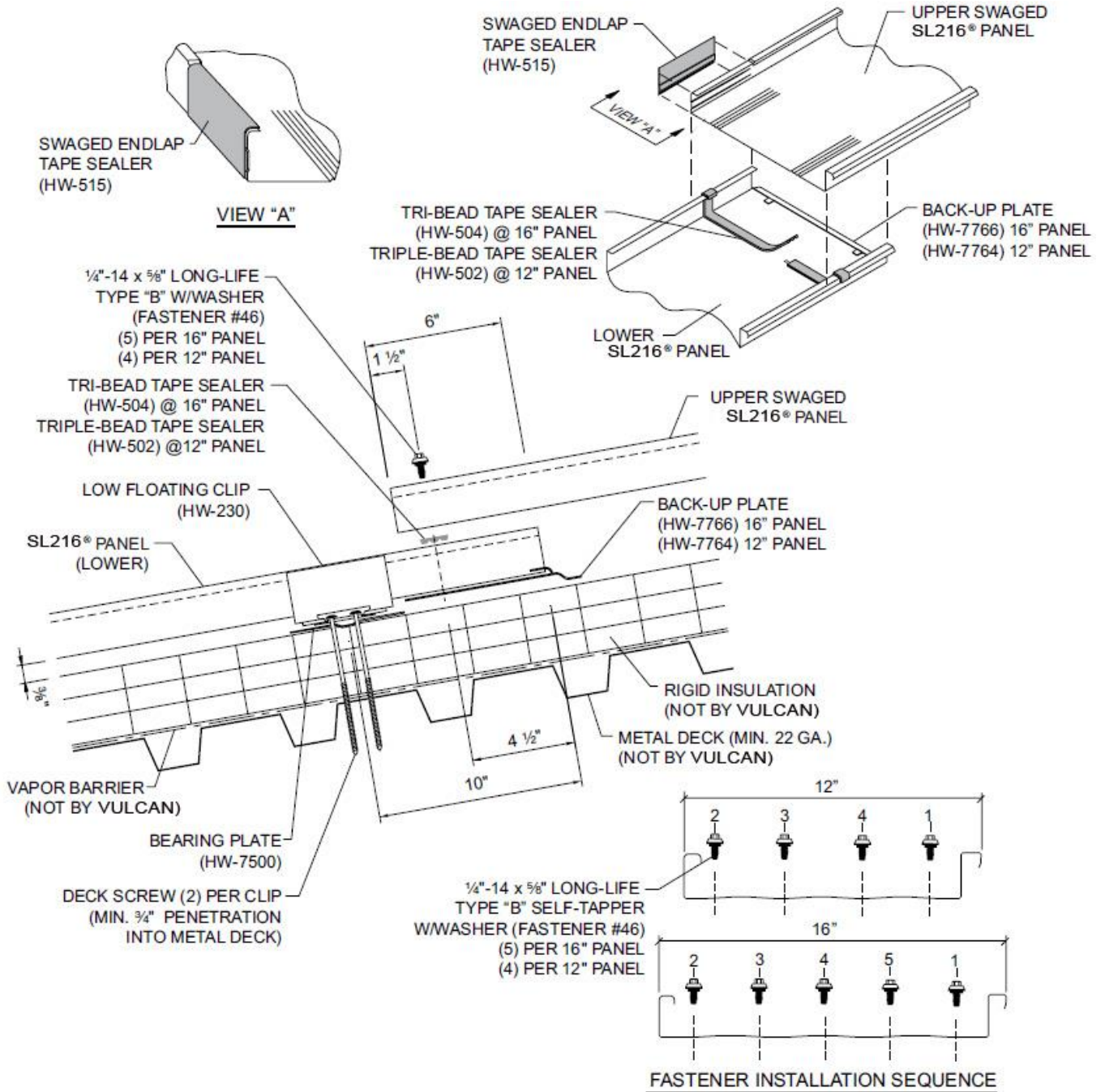

DETAILS

RIGID INSULATION OVER METAL DECK FLOATING EAVE WITH BOX GUTTER

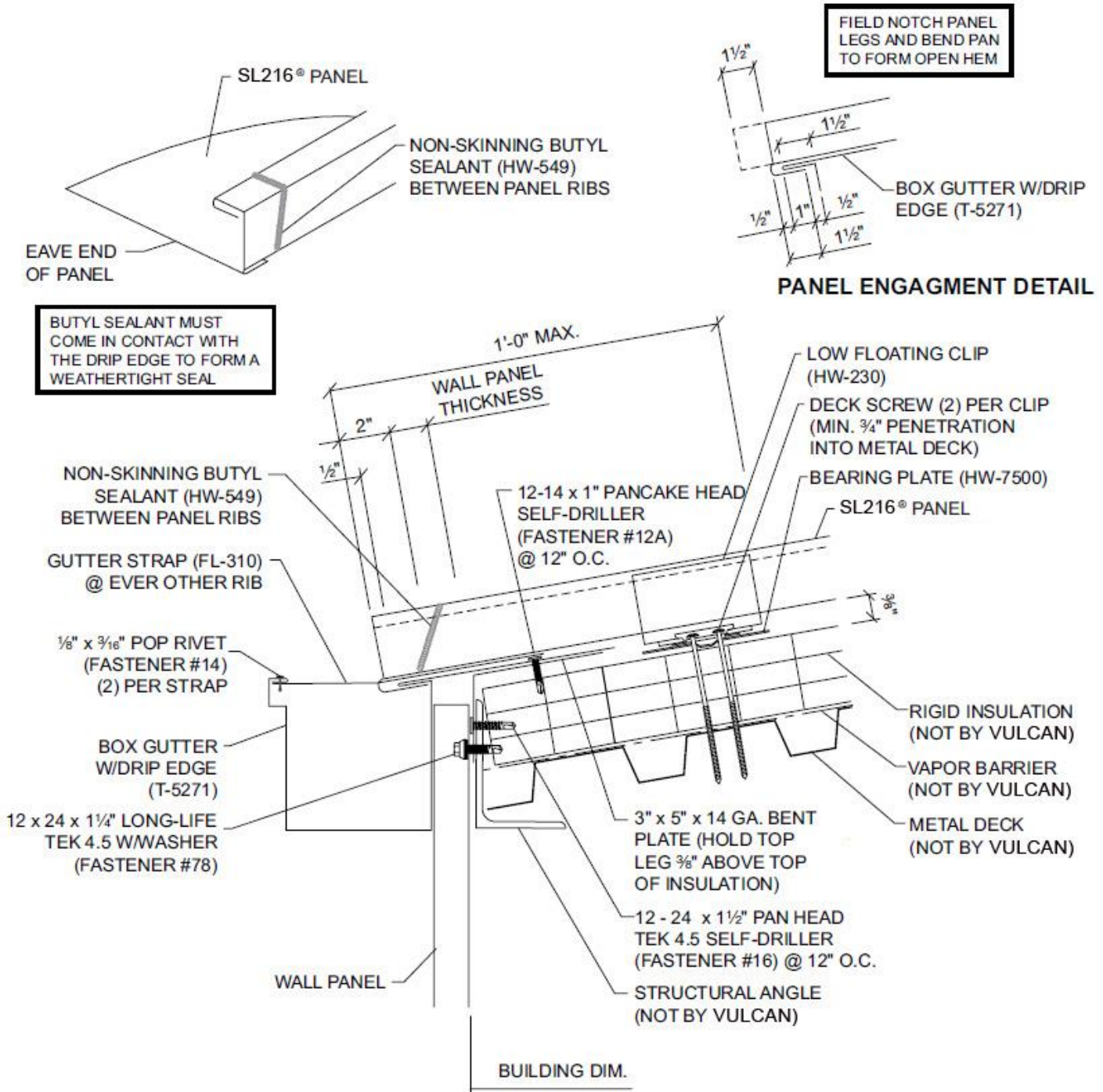

DETAILS

RIGID INSULATION OVER METAL DECK FLOATING EAVE WITH EAVE TRIM WITH EXTENDED DRIP EDGE

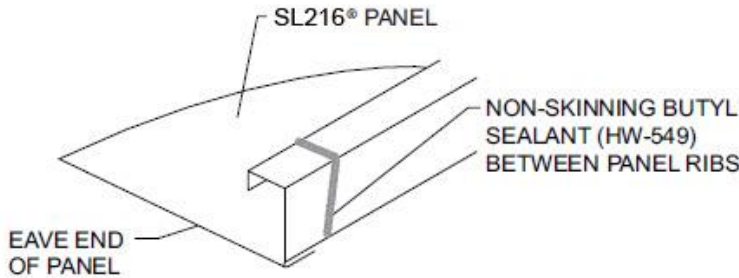

BUTYL SEALANT MUST COME IN CONTACT WITH THE DRIP EDGE TO FORM A WEATHERTIGHT SEAL

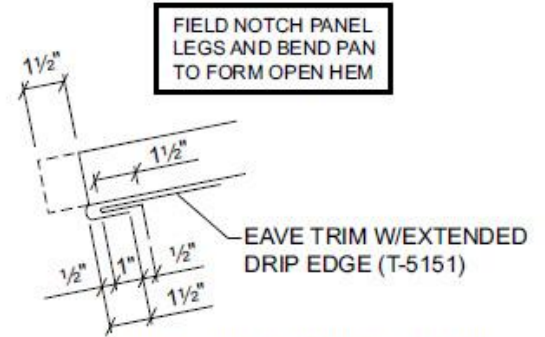

PANEL ENGAGEMENT DETAIL

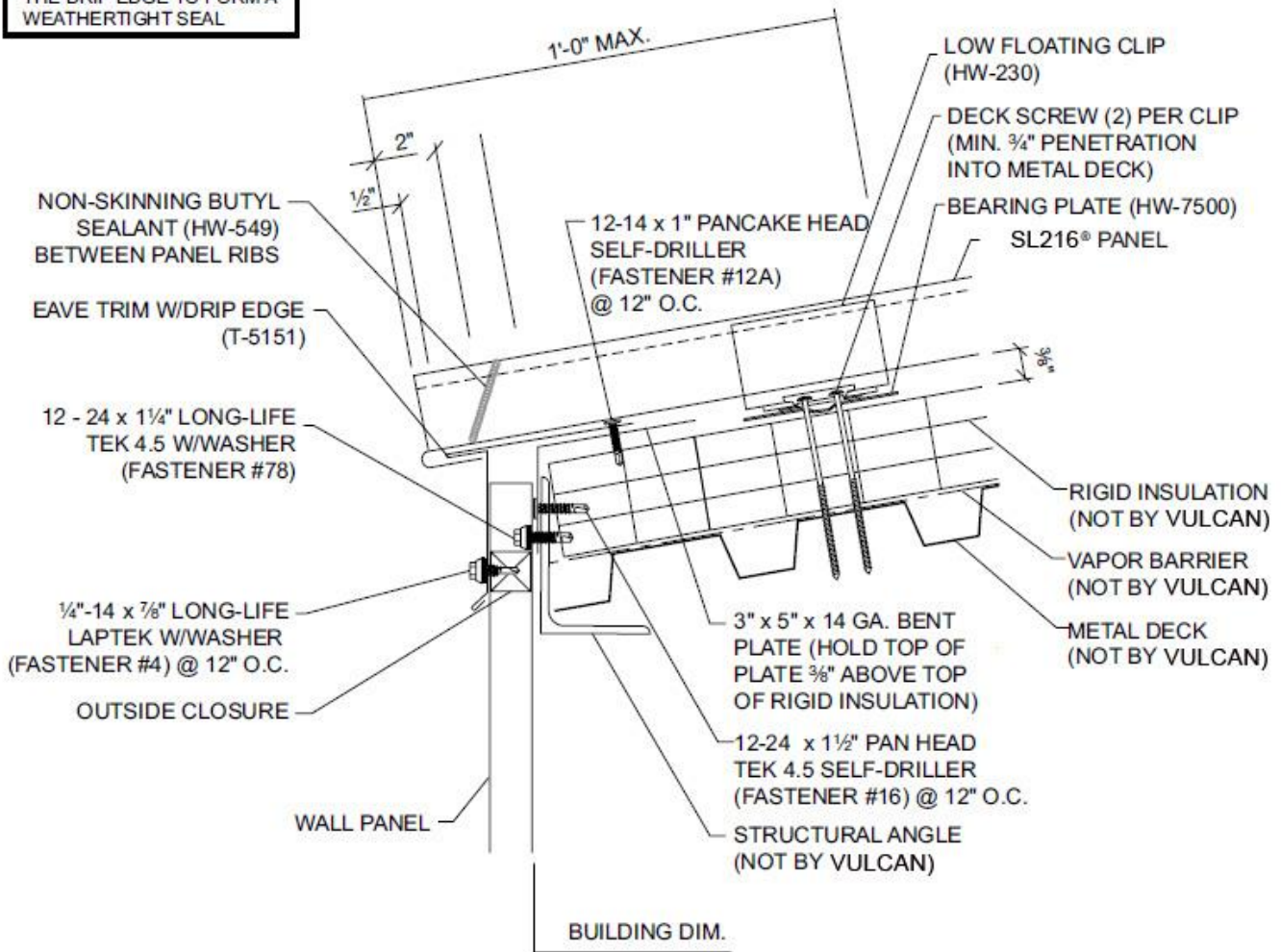

DETAILS

RIGID INSULATION OVER METAL DECK FIXED RIDGE

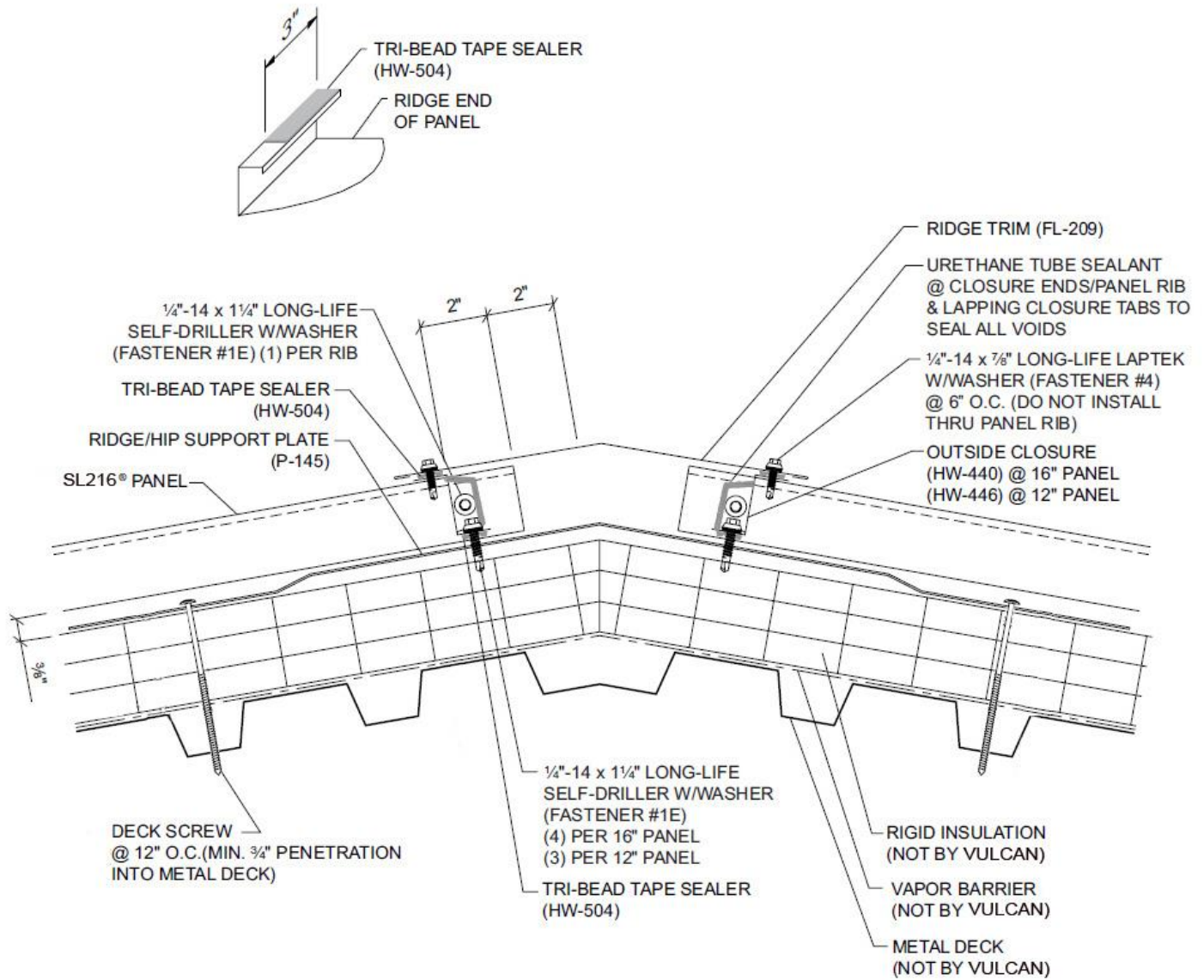

DETAILS

RIGID INSULATION OVER METAL DECK FIXED VENTED RIDGE

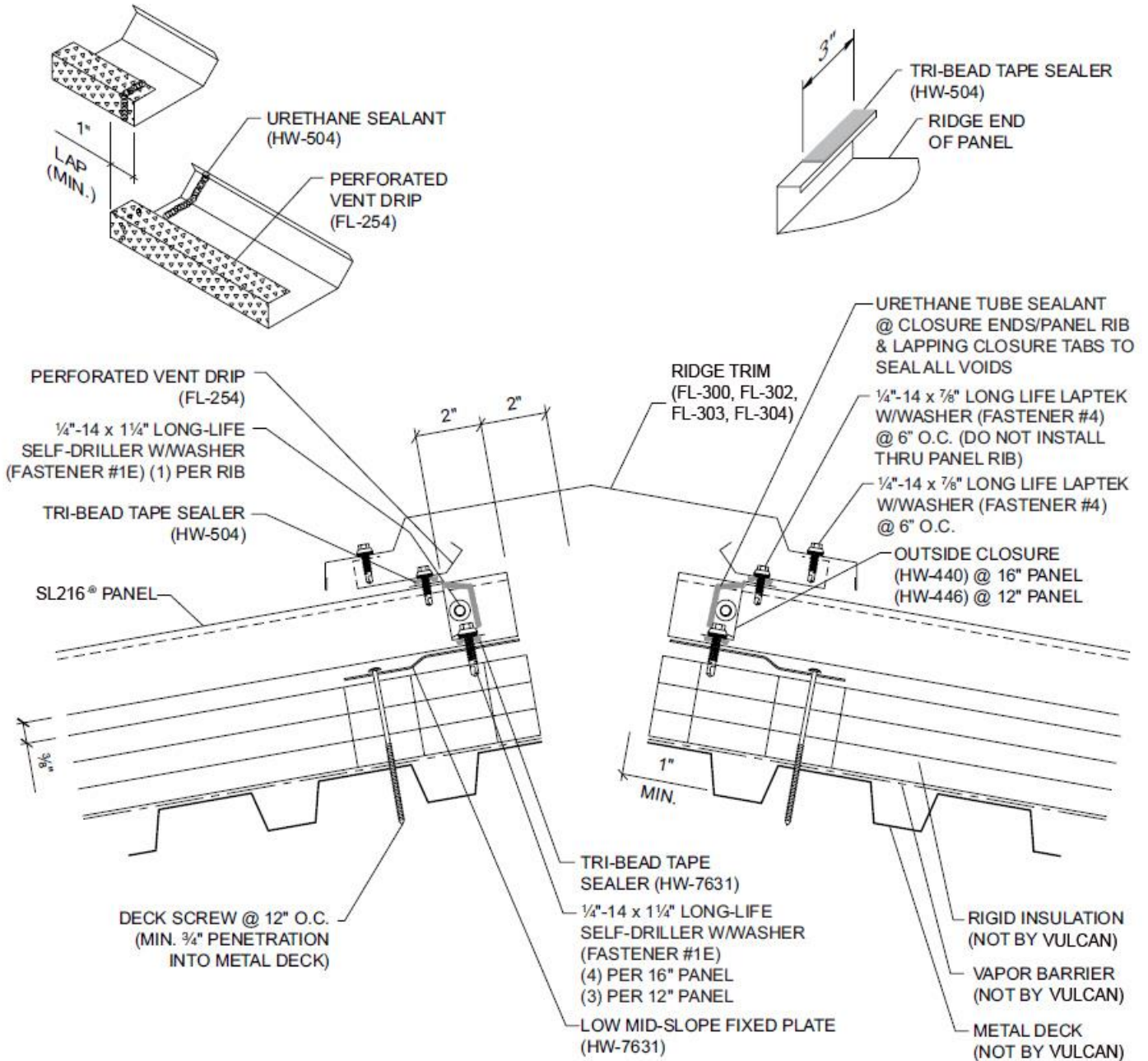

DETAILS

RIGID INSULATION OVER METAL DECK BOX RAKE

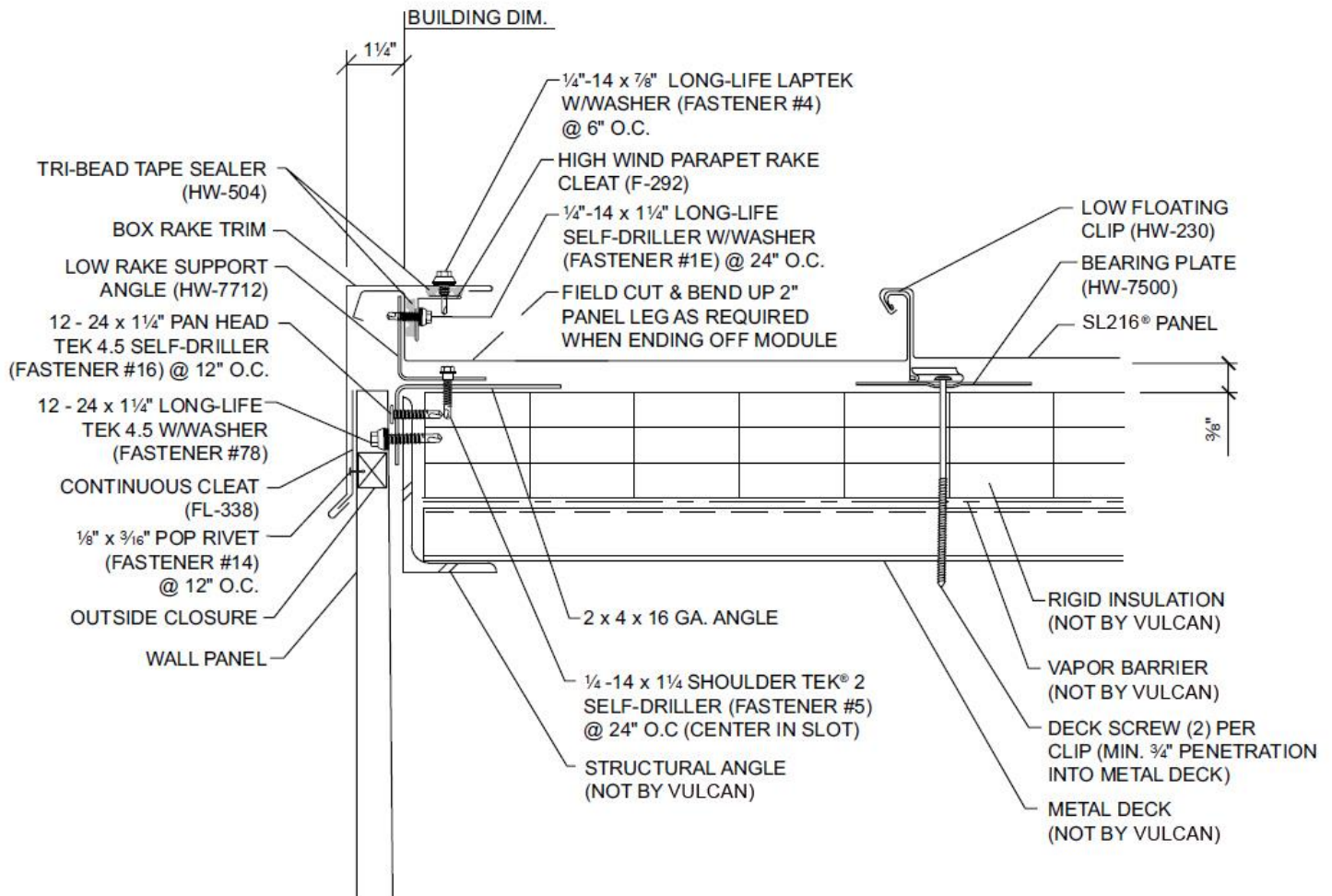

DETAILS

RIGID INSULATION OVER METAL DECK PARAPET RAKE

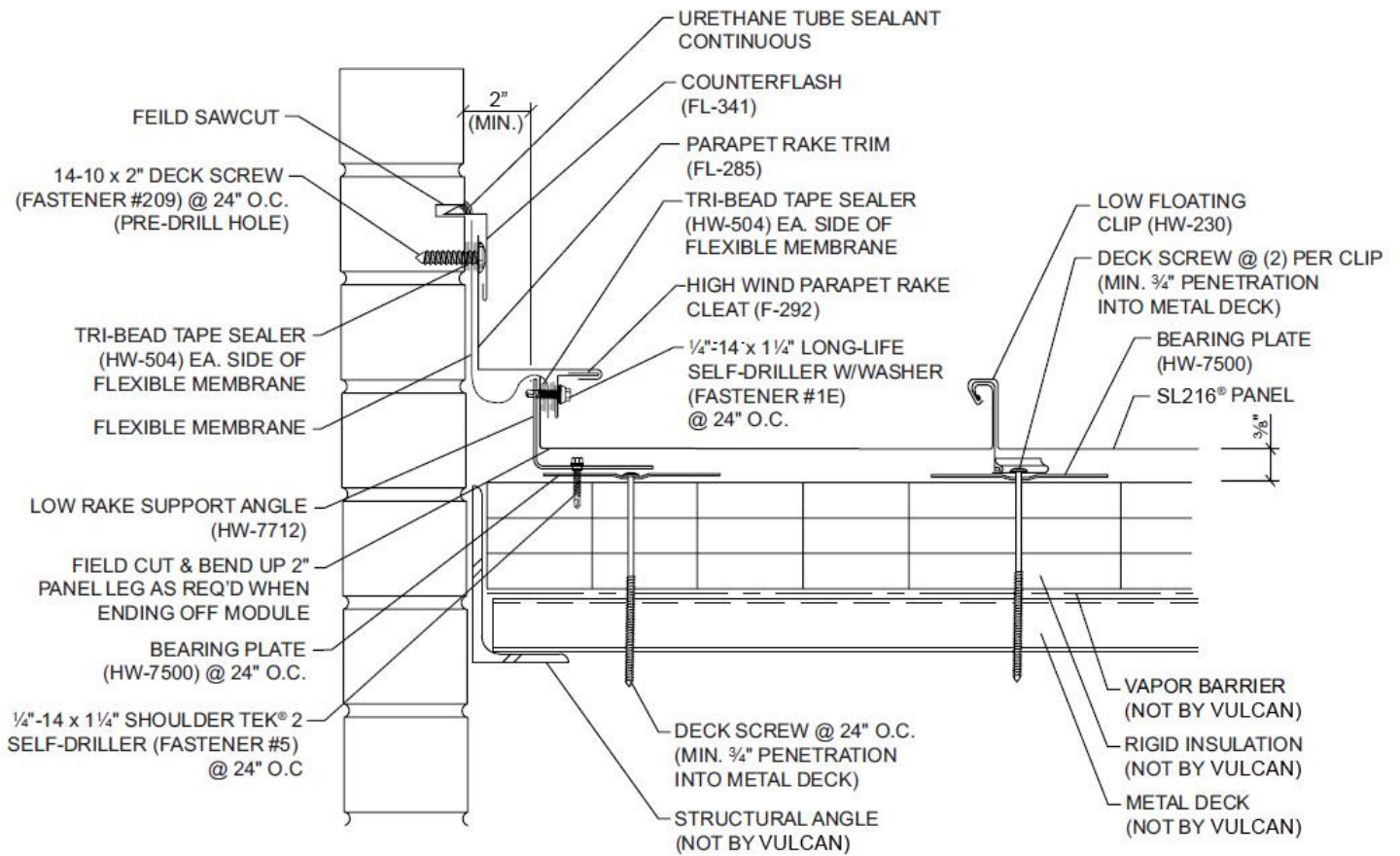

DETAILS

RIGID INSULATION OVER METAL DECK FIXED BOX HIGH SIDE EAVE

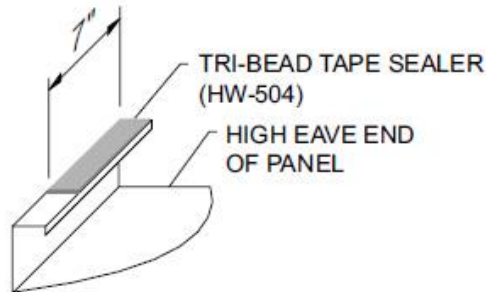

HIGH EAVE SEALANT DETAIL

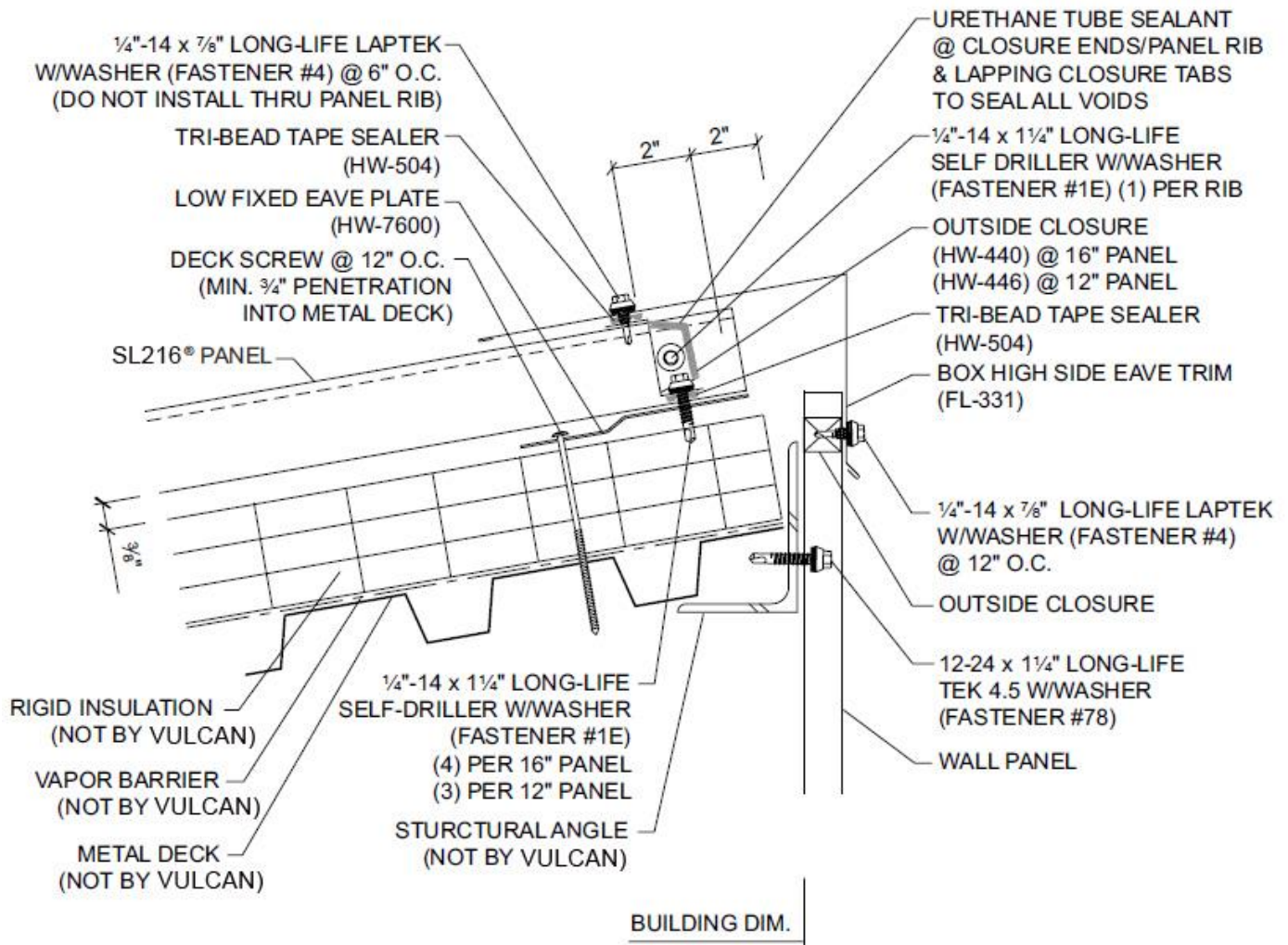

DETAILS

RIGID INSULATION OVER METAL DECK PARAPET FIXED HIGH SIDE EAVE

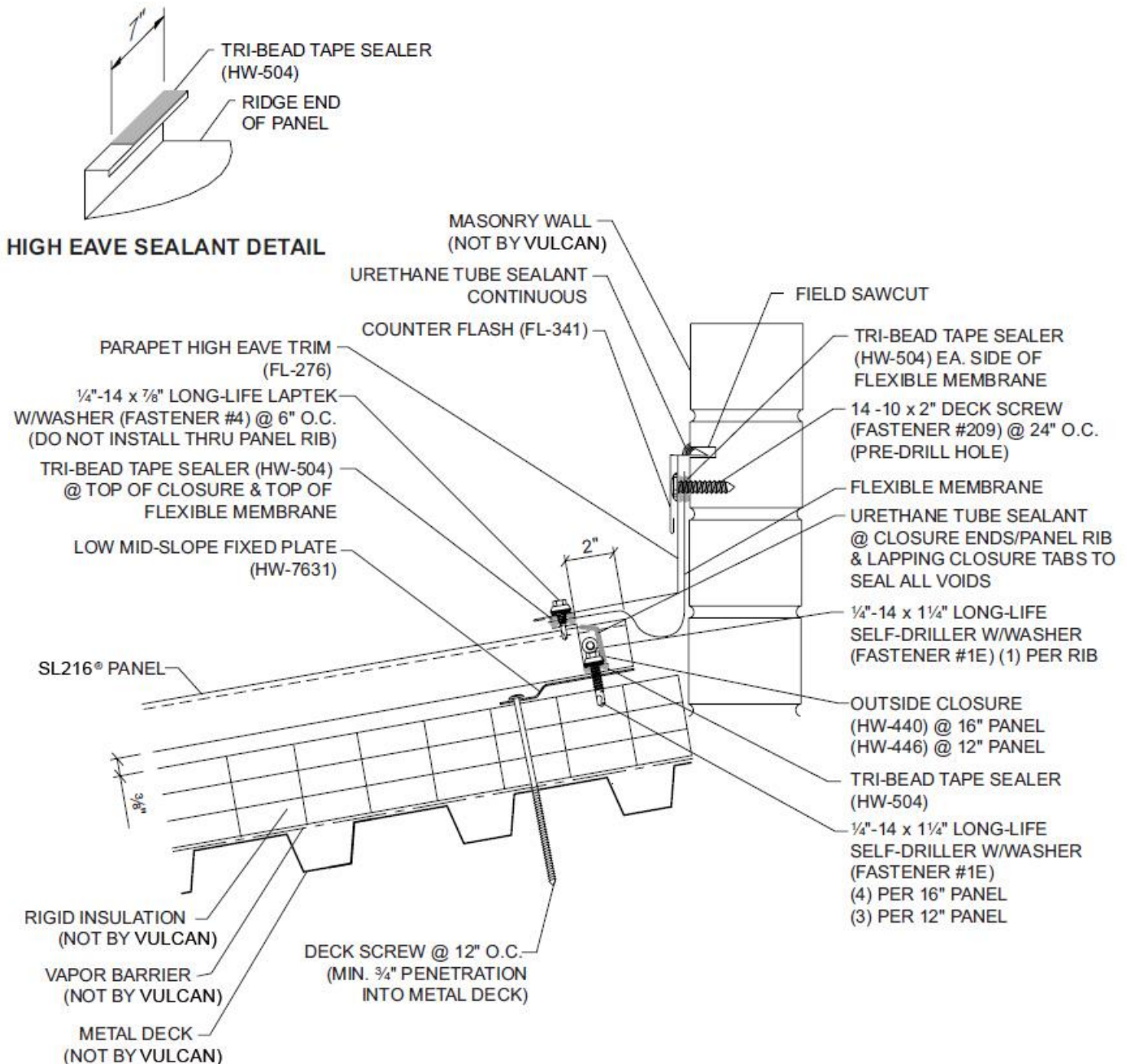

DETAILS

RIGID INSULATION OVER METAL DECK FLOATING VALLEY

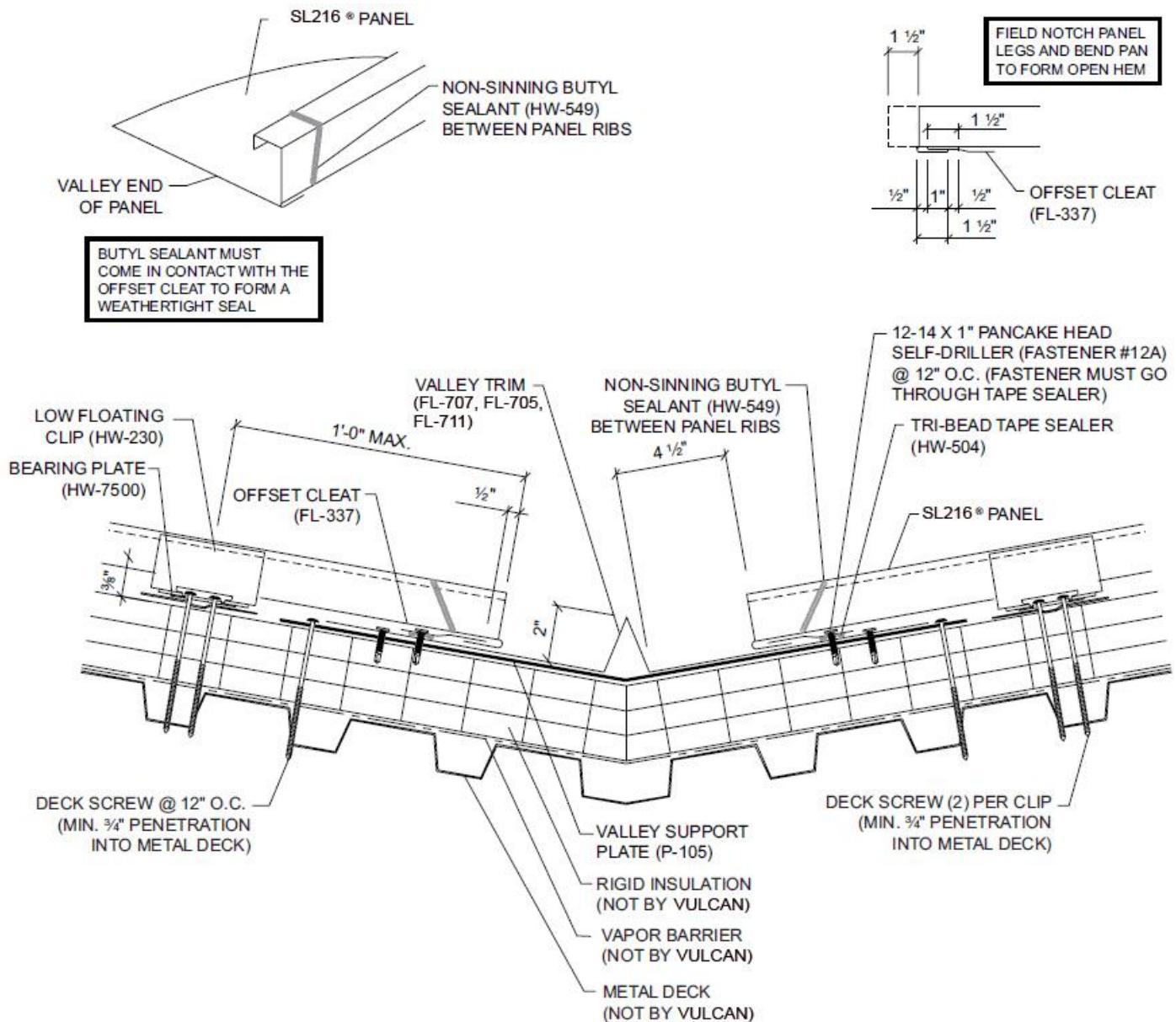

NOTE: DO NOT USE THIS DETAIL ON ROOF SLOPES LESS THAN 3:12

DETAILS

RIGID INSULATION OVER METAL DECK

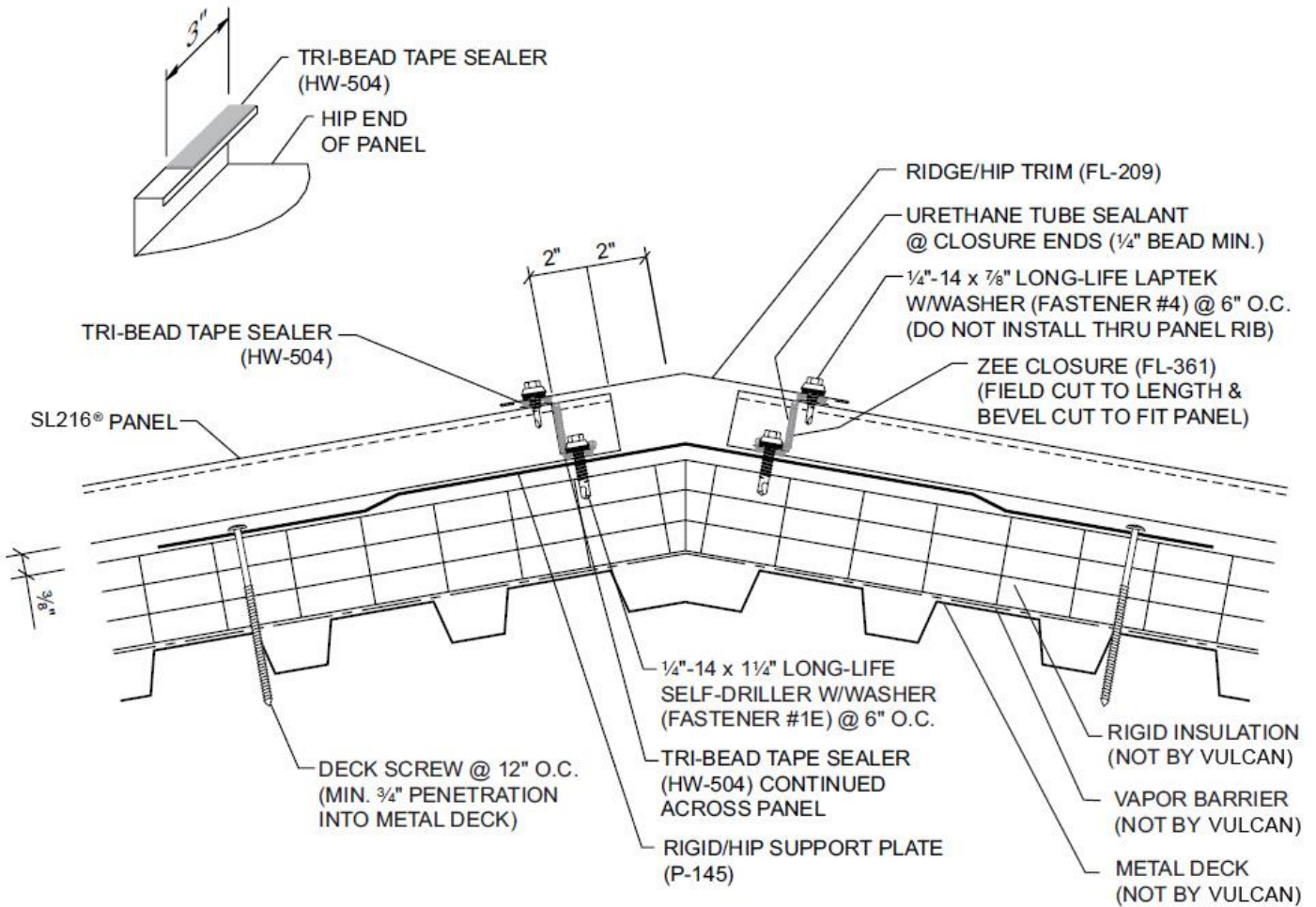

NOTES

For the most current information available, visit our Web site at www.vulcansteel.com